

CATALOG

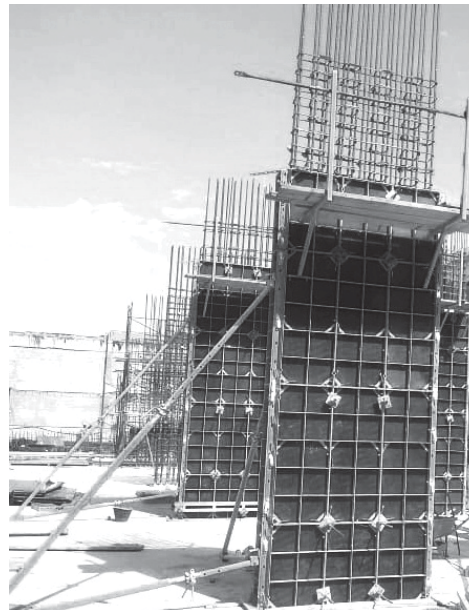

BUILD **STRONG**, BUILD WITH **QUALITY**

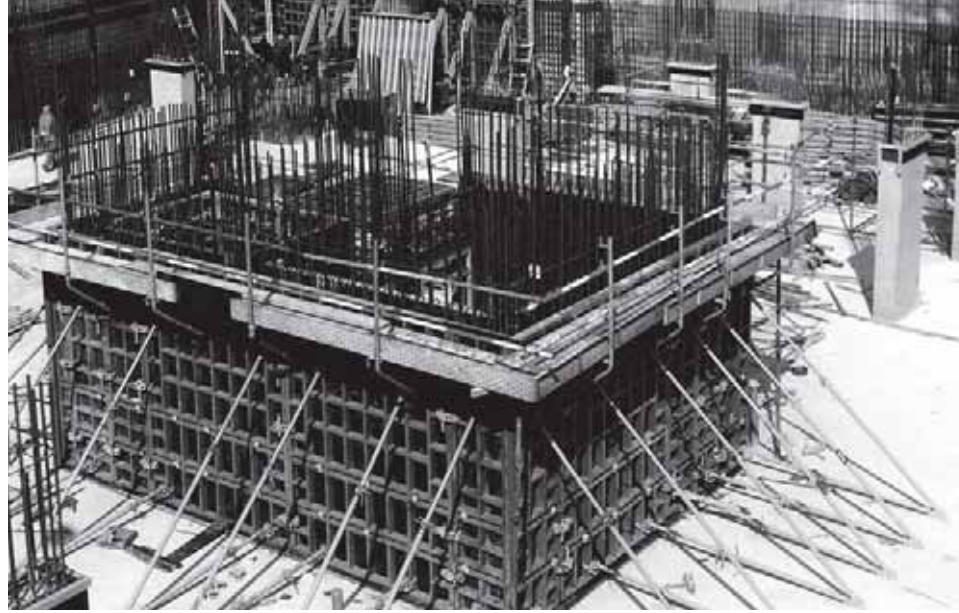

AL DHABI SCAFFOLDING & FORMWORK LLC

MANUFACTURER, RENTAL AND ERECTION OF SCAFFOLDING / FORMWORK SOLUTIONS AND OTHER STEEL FABRICATION



Build Strong

Build with Quality



Al Dhabi Scaffolding & Formwork L.L.C. (ADSF) is an established and reputable name within the scaffolding & formwork industry. We have been in operation in the United Arab Emirates for over 20 years with our head office in Dubai and factory in Umm Al Quwain.

At ADSF, our company ethos is to “Build strong, build with quality”, and this gold standard has led us to become one of the major providers of construction products.

ADSF is the sole distributor and patent holder for the Tabla quick release panel system in the Middle East. This unique shoring system is the fastest panel system in the world today. It is 14 times faster than conventional modular shoring systems, which provides our customers with a faster construction cycle.

Our present products and comprehensive services range are as follows:

- ◆ Tabla slab panel with quick release system
- ◆ ADlock support system with aluminum beam
- ◆ Heavy duty shoring frames for high floors with aluminum beams or Tabla panel
- ◆ ADX Alupanel Formwork System
- ◆ Tabla panel wall system (TB1) - Heavy Duty
- ◆ Tabla panel wall system (TB2) - Light Duty
- ◆ Gang wall system
- ◆ ADlock scaffolding system
- ◆ Medium and Heavy duty props
- ◆ Light & Heavy duty mobile towers
- ◆ All scaffolding fittings, tubes & accessories

TABLA Slab Panel Formwork	1 to 31
TABLA Wall Panel Formwork	
• ADX Alupanel System	32 to 63
• Tb1 Heavy Duty Panel	64 to 85
• Tb2 Light Duty Panel	86 to 96
• Gang Wall Formwork	97 to 103
Ad Lock Scaffolding System	104 to 111
ADSF Shoring Frames	112 to 115





ADSF Group of Companies

ADSF has core companies that provide the following services:

- Scaffolding & formwork rental
- Manufacturing and steel fabrication

Each company has its own dedicated team of experts. Our goal is to provide our customers with high-quality economic building solutions.

Note: All data mentioned in this catalogue are for reference purposes only. The manufacturer has the right to change specifications based on design and engineering.

OUR COMPANIES



ADSF Rentals

ADSF Rental Division designs and supplies all false work, formwork and scaffolding requirements.

Our client list of repeat business is a testament to our capabilities and customer service throughout the years.



Hallams Engineering & Manufacturing

Our dedicated manufacturing capability puts us at the forefront of scaffolding suppliers in the UAE.

Each components is expertly designed and produced to with stand harsh construction environments, providing years of reliable use and service.



ADSF
AL DHABI SCAFFOLDING & FORMWORK LLC



TABLA Slab Panel System

Safer, Easier, Faster & Cost Effective system in the "WORLD"



TABLA Modular Panel Shoring System



The TABLA Modular Shoring System



TABLA Slab Panel

The TABLA Modular Shoring System is a high octane, high performance engineered modular panel shoring system.

Tabla offers faster erection and stripping than can ever be expected from conventional shoring systems. It begins with rigid panel construction that enhances handling. The Tabla Prop with its integrated drop-head solution, helps to ensure confidence when erecting and makes stripping effortlessly all while leaving your back shoring in place and undisturbed. All these advantages result in a high rate of production.

The Panel and Prop have been designed to form a rigid interlocking system when erected that no bracing is required. The system is also designed to have a locking key feature that can withstand near hurricane wind speeds.

The standard TABLA Modular Shoring System is a unique system erected from the working floor up to a height of 16'6"/5030. Tabla can accommodate drop beams, drop heads, and any other engineering designs that are not regular to a flat slab.

This brochure will show you the simplicity of our Shoring System as well as the minimized number of components required for the erection and dismantling process.

The simplicity of the TABLA system shown being erected, right and left, is the key to its speed and safety.

On a grid of 4'x8'/2400x1200 TABLA can support 14"/355* of concrete including live load with a safety factor of 3:1.

On a grid of 6'x4'/1800 x 1200 TABLA can support 22"/558* of concrete including live load with safety factor of 3:1.

On a grid of 4'x4'/1200 x 1200 TABLA can support 34"/863* of concrete including live load with a safety factor of 3:1.

*Prop rating at a height of 11'6"/3505



The TABLA System: Safe, Fast, Efficient



Below are the three simple steps* to erecting the TABLA Modular Shoring system from the safety of the working floor.



Step 1

The Panel is hung onto the Prop.

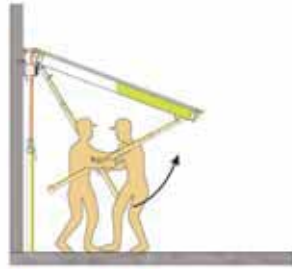

Step 2

The Panel is rotated (lifted) to the horizontal position and supported with the ADT.



Step 3

Next the Prop is slipped into position, locking into and supporting the Panel.

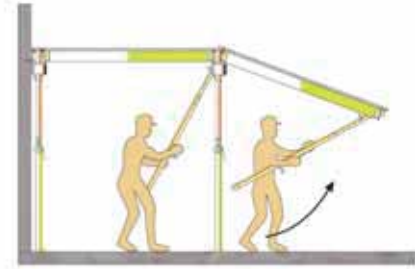

Erection continues by repeating steps 1,2 and 3

BUILD STRONG BUILD WITH QUALITY

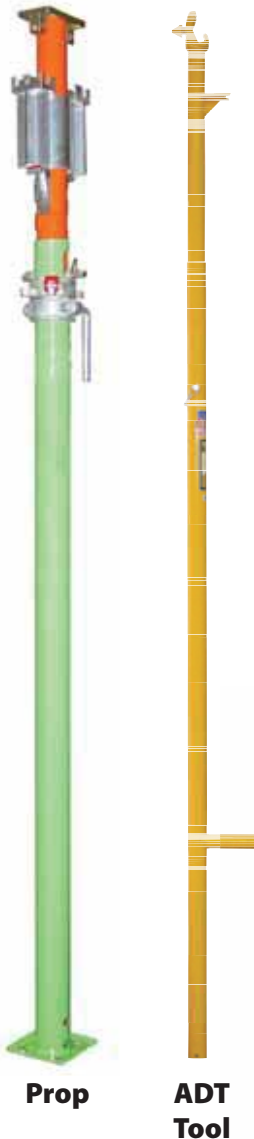

Prop

**ADT
Tool**

The Standard TABLA Shoring System is a unique system erected from the working floor up to a height of 12'/3658. With Prop Extension the system can be erected up to a height of 16'/4877. For higher floors see the TABLA Pioneer System on page 22. TABLA Shoring can accommodate drop bands, drop heads and its design allows for all interruptions.

The TABLA Prop with its integrated Drop-head ensures ease of erection and stripping, while back propping remains undisturbed. TABLA Props are available in two sizes: 10'-0"/3280 mm and 12'-0"/3936 mm. In addition, there is a Prop Extension which, when coupled with a TABLA Prop, allows for additional height of 4'-6"/1476 mm. Our Prop features numbered adjustment holes, and an all new quick release reshore base.

The TABLA Panel features a specially designed TABLA Fastener which allows for the KD (knocked down) option for container shipping overseas. This also makes it a snap for qualified personnel to replace damaged components. The new design will work with existing TABLA components. In addition, the TABLA Panel features a powder coated, colour coded finish for quick identification between side and end rails of the panel. Simply match colours during erection.



Panel

Please contact ADSF regarding the replacement of damaged components. Always use Genuine ADSF Components; never use substitutes.

For maximum performance and detailed information, review this manual in its entirety.

* ADSF recommend a minimum of 2 operatives for the assembly.

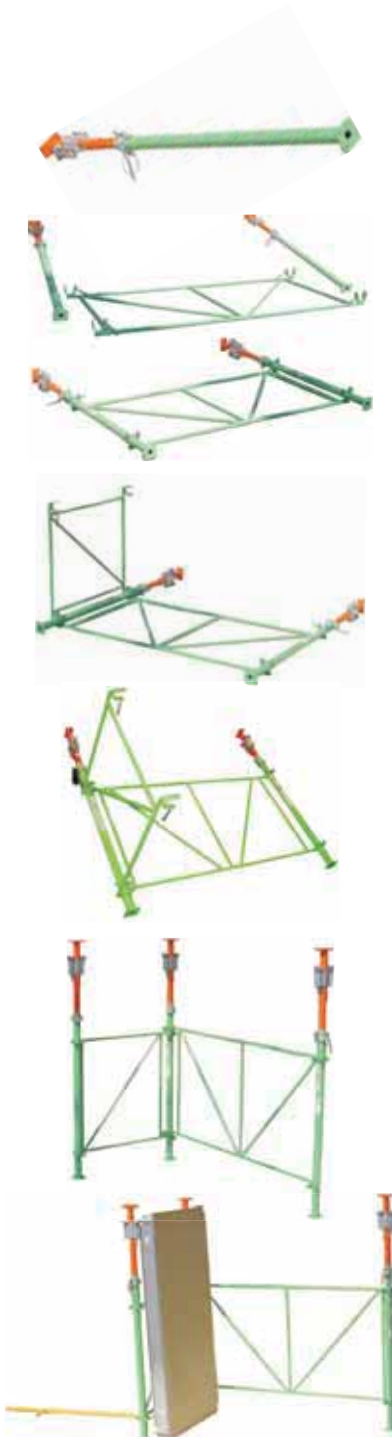

Step 1

Step 2

Step 3

Step 4

Step 5

Step 6



Insert shows ADT inserted in panel.

The minimum formwork crew size required to erect TABLA is two men*. The illustrated assembly procedure can be started anywhere on the working floor of the job site (i.e.: at column locations, middle of bay area, etc.).

System assembly using Gate Brace*

Step 1

Extend Props to required working height and insert the Quick-Release Locking Pin.

Step 2

Prepare Bracing Gates to build an "L" shaped tower by assembling one Bracing Gate and two Props. Insert and lock the Gate Brace to the Props utilizing the attached Wedges.

Step 3

Attach a second Gate Brace at 90° to one of the props in the same manner as in Step 2.

Step 4

Tilt the TABLA assembly into the upright position and prepare to attach the third Prop to the free end of the Bracing Gate.

Step 5

Square up the "L" shaped tower (3 Props and 2 Gate Braces).

Step 6

Hang the Panel on the two Props making sure that the legs of the Panel are firmly seated in the cups of the TABLA Head Assembly. Rotate Panel to allow insertion of ADT and continue to rotate upwards.





Step 7



Step 8



Step 9



Step 10

Step 7

With the ADT seated into the Panel, step 6, rotate the Panel into the horizontal position and support the Panel until the forth Prop is installed.

Step 8

Place the fourth Prop under the Panel corner socket and seat the Panel into the Prop Head.

Step 9

Hang the next Panel, as in step 6, and swivel to horizontal.

Step 10

With the ATD seated into the Panel (step 6) and the Panel rotated into the horizontal position use the ADT to support the panel temporarily until the next 2 Props are installed.

Bracing and blocking

In general, all structures require lateral bracing or lateral support. The TABLA Shoring System is no different. TABLA Shoring derives its lateral stability under load and before loading by "blocking", as construction proceeds, securely to the building's structural elements, walls, columns, cores, stairwells, etc. TABLA users can also use Wall Brackets, Wall Beams and Gate Braces. It is very important that the erector, understand the difference between blocking the system secure to the structure prior to pouring concrete, as opposed to the necessity to ensure that the system is laterally secured during the erection phase. With proper procedure TABLA Shoring can free stand during erection.

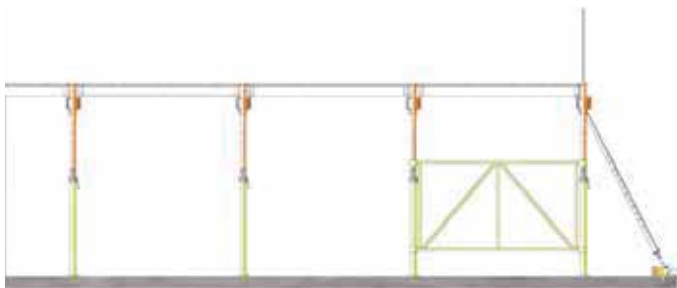

Diagonal Shear Brace is sometimes required, see your drawings

Long End Runs Brace Detail

Long end runs also require bracing (consult your layout drawings).



Blocking (typical example)

Stripping

Panel stripping

Once the pour has set, the panels can be removed for reuse without disturbing the shoring props.

Step 1

Pouring Position.

Step 2

Moving into position with ADT to unlock Panel support assembly.

Step 3

Engage the ADT.

Step 4

Panel support assembly is unlocked and has dropped away from Panel.

Step 5

Pull Panel down using ADT (both ends). Use notch and Stripping Bar if necessary to break bond.

Step 6

Panel stripped, level and engaged in all 4 cups.

Step 7

Push tail of panel up. Slide panel forward in cups clearing back cups.

Step 8

Feet remain in engaged cups. Lower (hinge) panel down.

Step 9

In position to remove Panel.

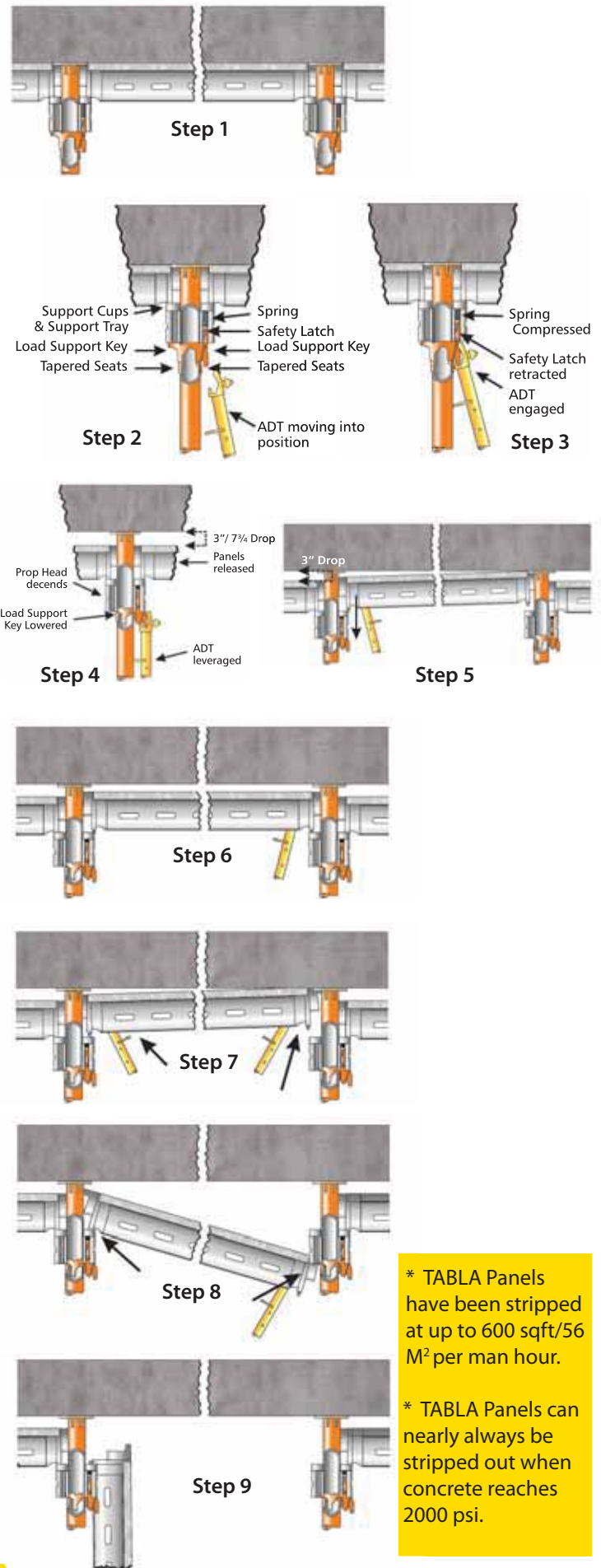

* TABLA Panels have been stripped at up to 600 sqft/56 M² per man hour.

* TABLA Panels can nearly always be stripped out when concrete reaches 2000 psi.

Stripping

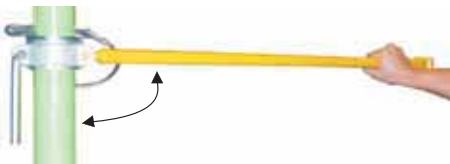

1
Insert Bar into notches on corners of panels.

2
Rotate Bar to release surface tension.

3
Insert Stripping Bar hook into Prop Collar. Rotate collar to raise and lower prop.

Stripping Bar

The TABLA Stripping Bar is a multi use tool, which can be used for the release of surface tension between the Panel Deck and the underside of the slab (see images 1 and 2).

The Stripping Bar can also be used as a "cheater bar" on the Prop Collar. (see image 3).



Stripping Bar.

Inertia Stripping Bar.

BUILD STRONG BUILD WITH QUALITY

Shoring, Backshoring and Reshoring

Typical multifloor construction process

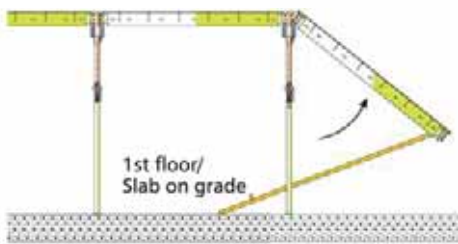

Step 1

Erect TABLA SHORING SYSTEM from floor slab.

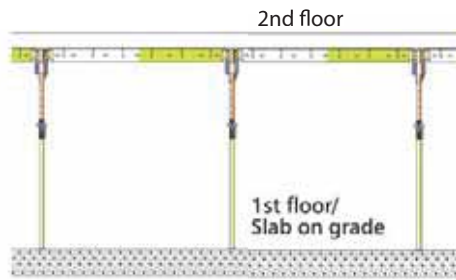

Step 2

Shoring complete, pour second floor.

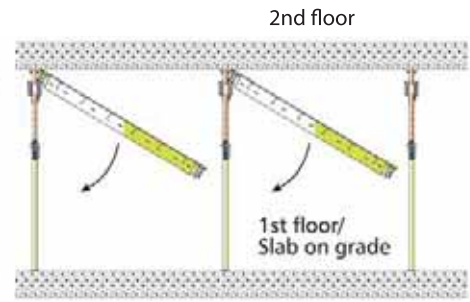

Step 3

Once concrete reaches 2000 psi, remove TABLA Panels. Leave TABLA Props undisturbed.

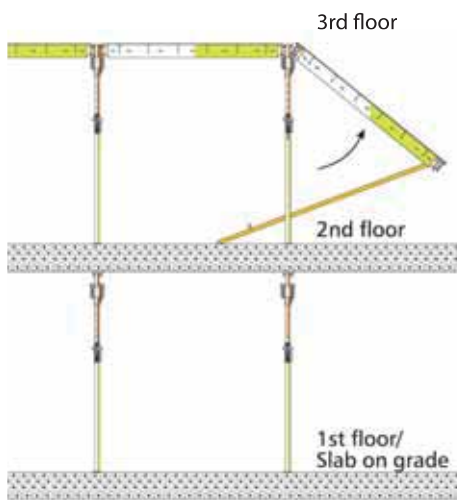

Step 4

Erect third floor with additional Props. Leave TABLA Backprops undisturbed.

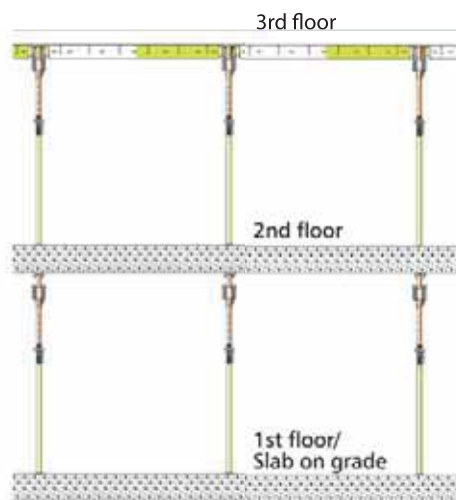

Step 5

Shoring for third floor complete, pour third floor.

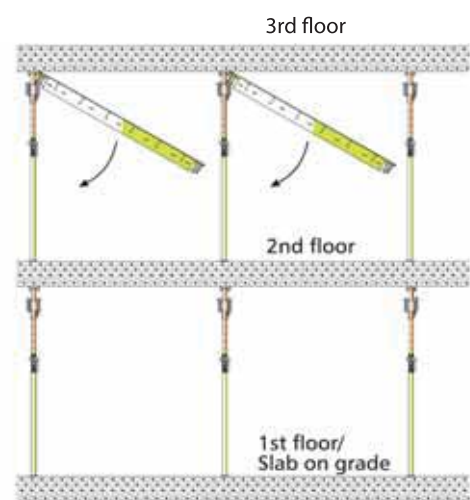

Step 6

Once concrete reaches 2000 psi, remove TABLA Panels from third floor. Leave TABLA Props undisturbed.

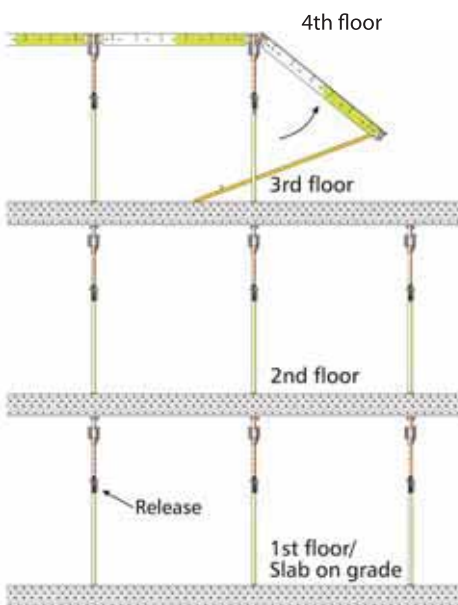

Step 7

Erect 4th floor with additional Props.



Step 8

Convert the lowest level of Props from backshoring to reshoring by striking the Quick Release above the Prop Collar.

Release the load in the section as required by site Engineers. Allow the floor to "Take Up" self weight then snug up the Props.

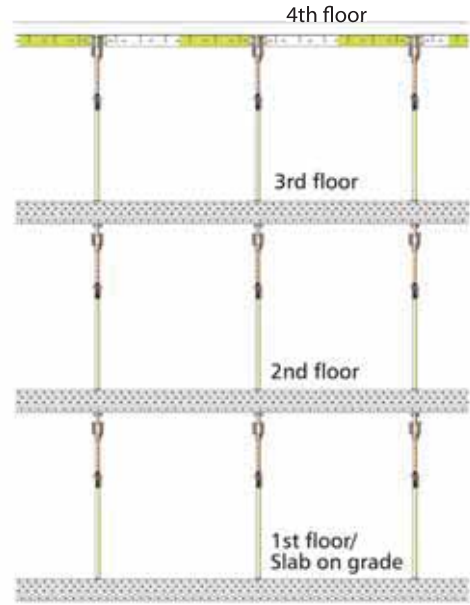

Step 9

Shoring for fourth floor complete, pour fourth floor.

Shoring, Backshoring and Reshoring



BUILD STRONG BUILD WITH QUALITY

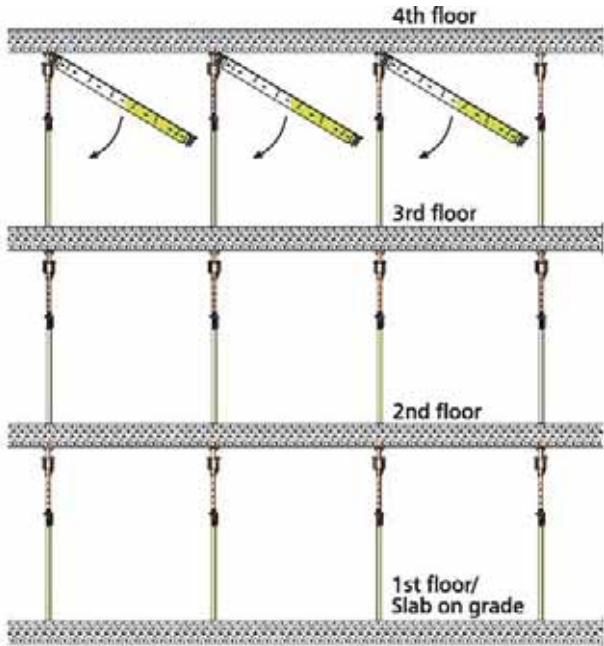

Step 10
Once concrete reaches 2000 psi, remove TABLA Panels from under forth floor. Leave TABLA Props undisturbed.

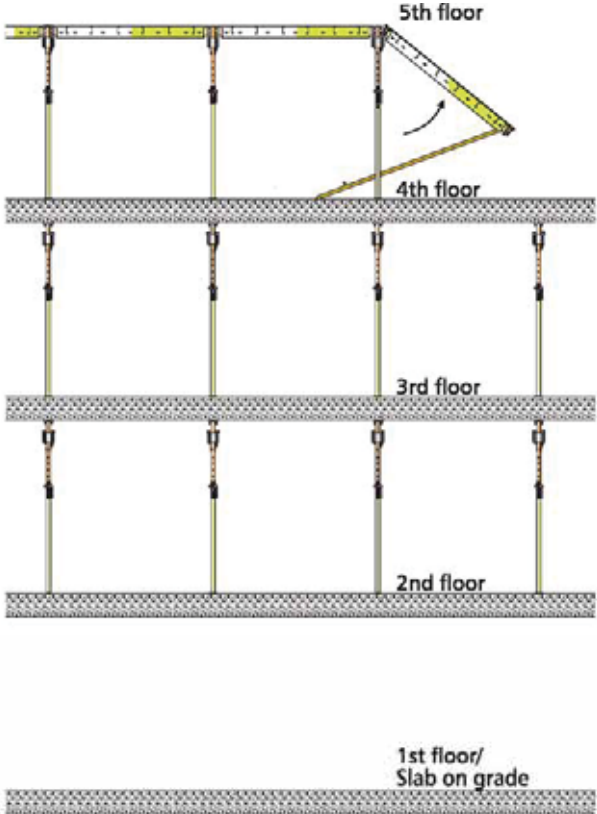

Step 11
Remove Props supporting second floor and recycle them to the forth floor.



TABLA Cantilever System

TABLA's Cantilever technology maximizes efficiency and provides excellent safety on slab edges. **Edge Cantilever construction is a potentially dangerous place to erect and work.** Cantilevered Panels can create a great wind sail and it is estimated that uplift wind on tall buildings can be as high as 40 lbs per sq. ft/195 kg. per square metre or can create a force greater than 120 mph/190k/hr wind. Properly installed, the TABLA Cantilever System is designed to overcome these forces and when used correctly provides a safe working environment along with its unique fast and efficient erection.

Note: Safety chains **MUST** be installed **before** out-board Panels are raised. Safety Toggle Pins are installed with each installation of the Cantilever Post to Panel.

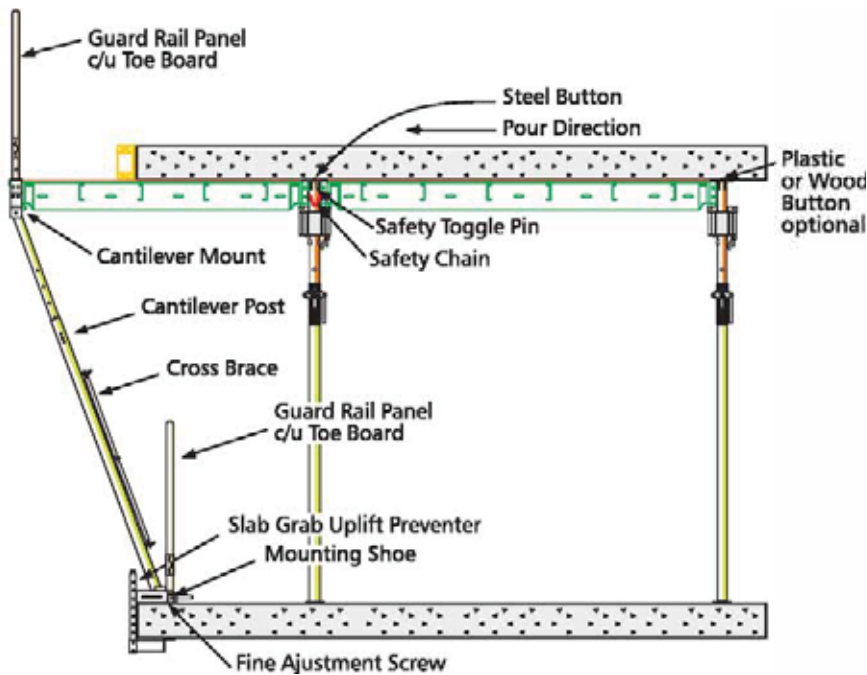
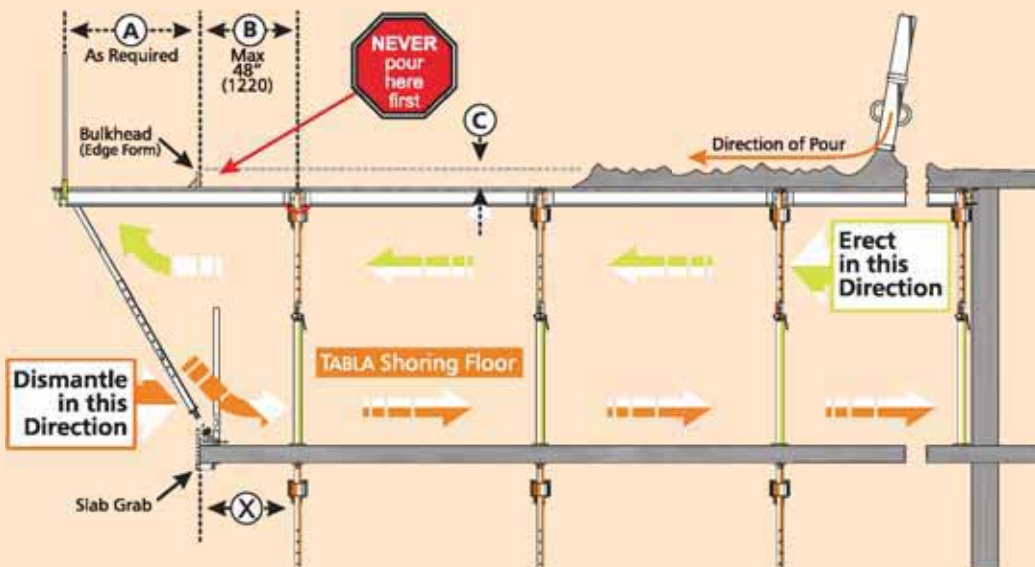

Use personal tie off safety lanyards when working with Cantilevered equipment.

Check drawings for exact details.

For Cantilevers greater than 60 degrees, consult engineering.

Safety Note:

Always be tied off when working with cantilevered panels.

Cantilever Erection

Erection of Cantilever



Edge Mounting Shoe

Step 1

Obtain PPE as per method statement for work and comply accordingly.

Step 2

Hang panel in vertical position and install safety chain (2 per panel) through accessory holes between vertical panel and horizontal panel.

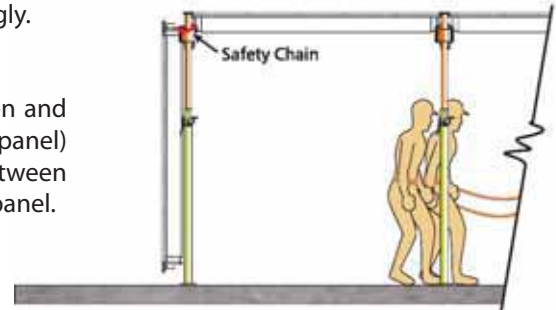

Step 3

Install Cantilever Mounts, Cantilever Posts, Cantilever Shoes, Cross Brace, and upper Guard Rail Panel.

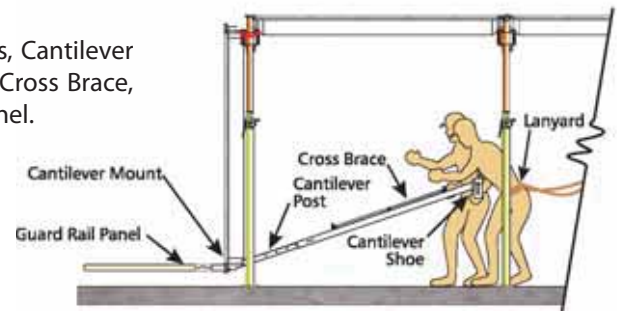

Step 4

After tying off for personal protection, rotate panel into horizontal position using Cantilever Posts.

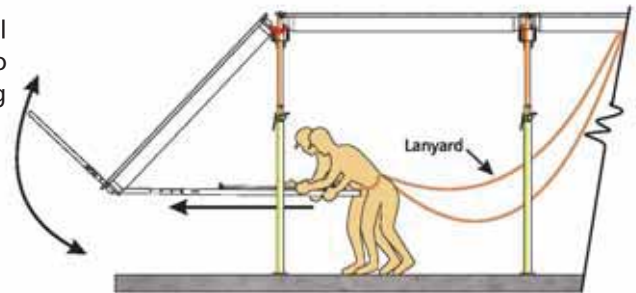

Step 5

Install Cantilever Shoe, securing it with a Slab Grab, then install the Cross Brace and Guard Rail.

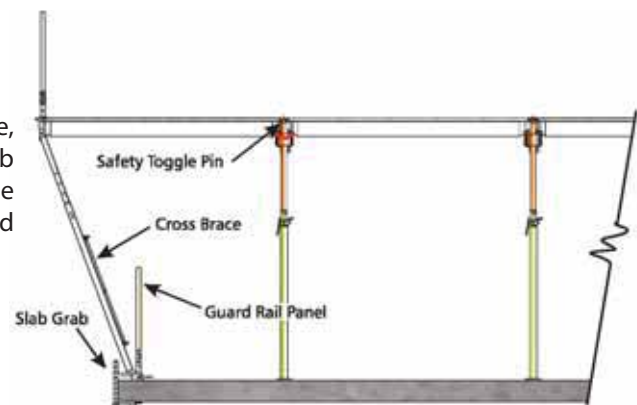

BUILD STRONG BUILD WITH QUALITY

Cantilever Stripping

Stripping procedure for reinforced concrete Cantilevered Panel

- 1 Leave safety chains in place and remove Safety Toggle Pin. Release the Load Support Key using the ADT Tool and drop the Panel.
- 2 While tied off with your Safety Lanyard, remove the lower Guard Rail.
- 3 Free The Mounting Shoe from the slab.
- 4 Using the Cantilever Post, rotate the Panel downward into the vertical position.
- 5 Remove the remaining Cantilever components and recycle them to the next floor.

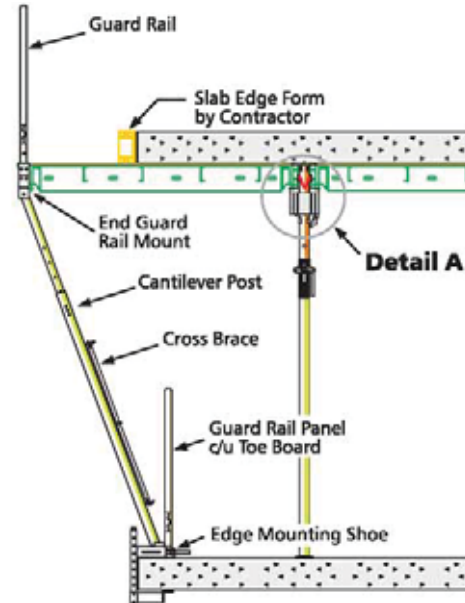

Detail A Poured Position

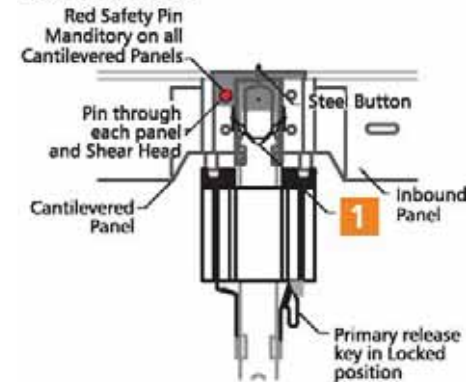

- 1 Safety chains, 2 per panel, in place between Cantilever Panel and Inward Panel. Place through accessory holes on end rails of Panels prior to the erection of Cantilevered Panel.



Stripping Procedure

Stripping procedure for post-tensioned Cantilevered Panel

- 1 Once concrete is up to panel stripping strength, release primary Release Key on the interior Props and lower Cup and Sleeve assembly.
- 2 Release primary Release Key on exterior Props adjacent to Cantilever Post. Lower Cup and Sleeve assembly. Cantilevered Panel end drops only 1/8". Inbound Panel drops 3". See **Detail B**.
- 3 Swing down inbound Panel and remove Safety Chains from inbound Panel only. Wrap Safety Chains around postshore linking them using the chain connector link. See **Detail C**. Lift inbound Panel out of Cups and remove from area.
- 4 After slab is post-tensioned and Cantilevered Panel is ready to be stripped, remove one pair of chains which are wrapped around postshore. Make sure Cantilevered Panel being stripped has one Safety Chain through it and is connected to other Panel around postshore.
- 5 Remove Shear Pins through Cantilevered Panel by pushing upward on panel 1/8". Swing Panel down into hanging position. Remove remaining Safety Chain and lift panel out of Cups. Do one Panel at a time. Repeat step 4 and 5 for the remaining Panels.

- 2 Swing inbound panel down and disconnect safety chains from it. Link safety chains together around postshore using chain connector link.

- 3 Safety chains, 2 per panel, in place between Cantilever Panel and Inward Panel. Place through accessory holes on end rails of Panels prior to the erection of Cantilevered Panel.

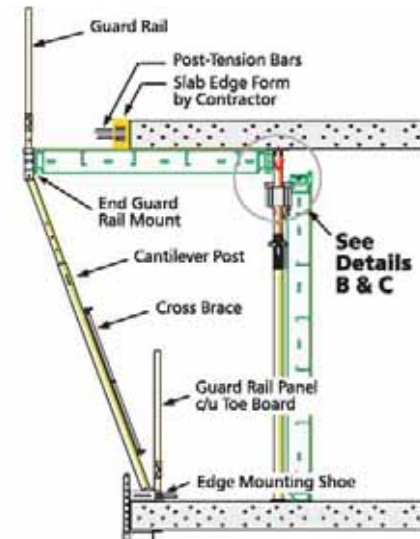

Detail B

Inward Panels Dropped.

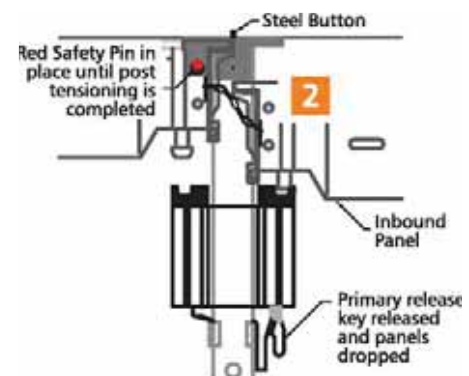

Detail C

Inbound Panel Swung Down, Safety Chains Connected.



TABLA Cantilever Red Safety Chain.

BUILD STRONG BUILD WITH QUALITY

Ramps

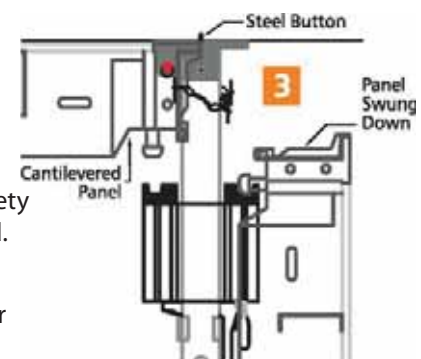

Concrete being pumped onto typical ramp constructed using TABLA Shoring.

The TABLA Shoring System has the unique ability to be used on ramps. To the right is a typical example of ramp erection.

Please note that terminus Shear Plate must be anchored to the concrete slab before a dead or live load is placed on TABLA Panels. Additional bracing is not required under sloped areas in single Prop arrangements of TABLA, provided that Shear Anchors or Shear Braces are firmly in place, and Panels are blocked at existing walls and columns (see layout drawings).

Shear load is accumulative when concrete is poured from top down. These calculations are based upon uphill pours. Consult the TABLA Engineering Department if poured downhill.

For conditions not shown in this brochure and or the Engineering Bulletin, contact the TABLA Engineering Department (TED).

When extreme conditions exist between slopes on the supporting slab and the supported slab, contact the TABLA Engineering Department.

When the supporting floor is not at the same slope as ramp above, wedges must be provided to maintain full bearing across the base plate.

Typical Ramp

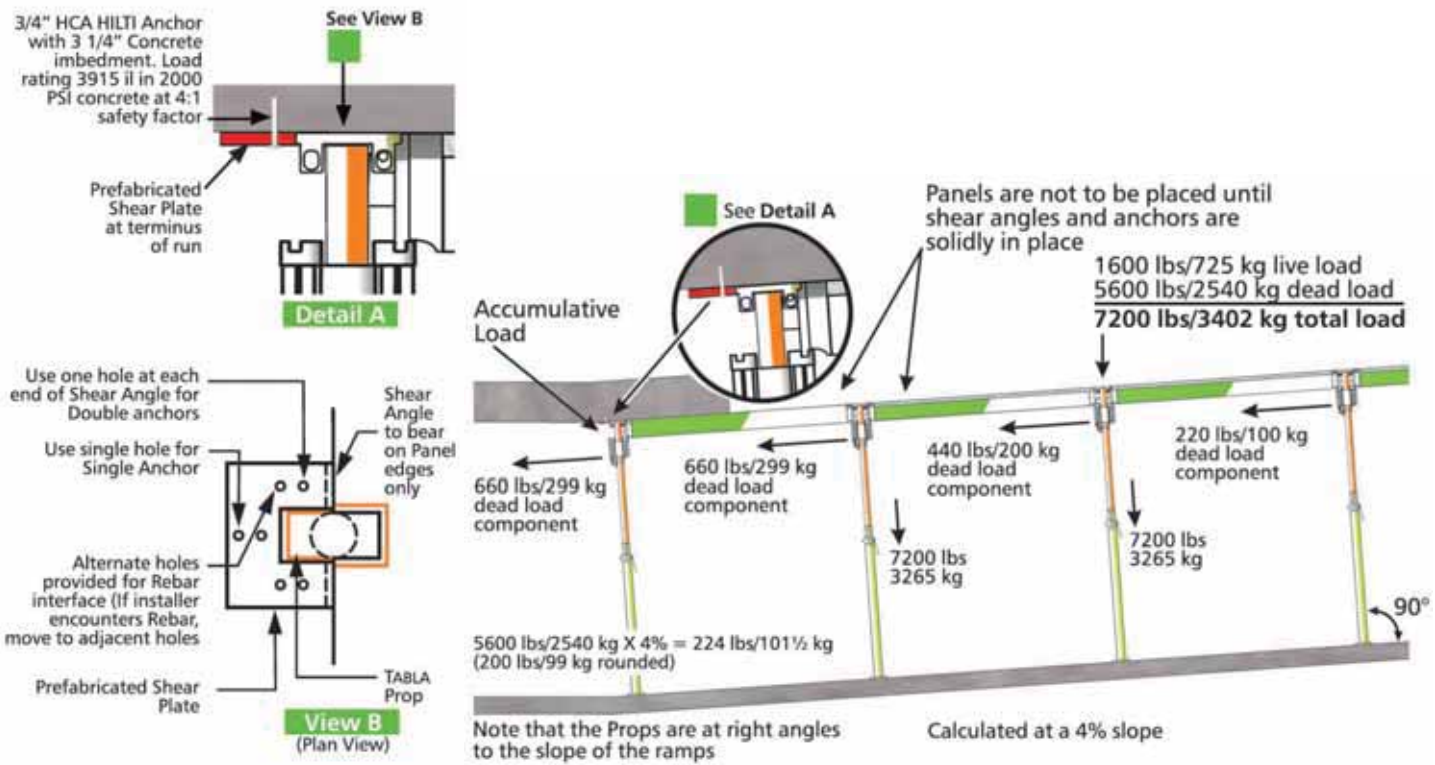

Alternate Ramp with Diagonal Shear Brace



Tabla Props must be shimmed with wedges to plumb for level deck above a ramp incline.

High Floor Shoring System

TABLA Pioneer is a high floor shoring system which allows you to go to any height (subject to shoring tower specifications). It can be erected using TABLA's Pioneer Head Assembly (Detail 1) or TABLA Prop (Detail 2). Either configuration can be attached to most standard shoring frames using TABLA's Pioneer Connector. The system allows for stripping of the Panels while backshoring remains undisturbed. The new TABLA Quick Release Reshore Base (Detail 3) attaches to most screwjacks using TABLA's Pioneer Screw Adaptor. This allows the system to provide shoring, backshoring and reshoring using the same principal as TABLA's Standard Shoring System. See pages 6 and 7 for more information regarding Backshoring and Reshoring.

Erection

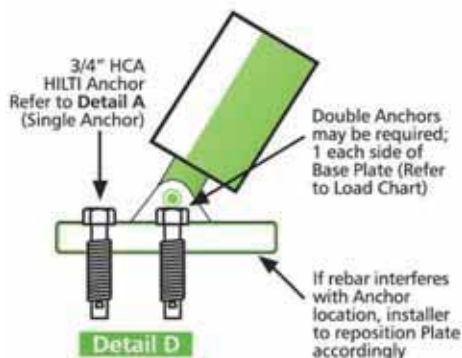
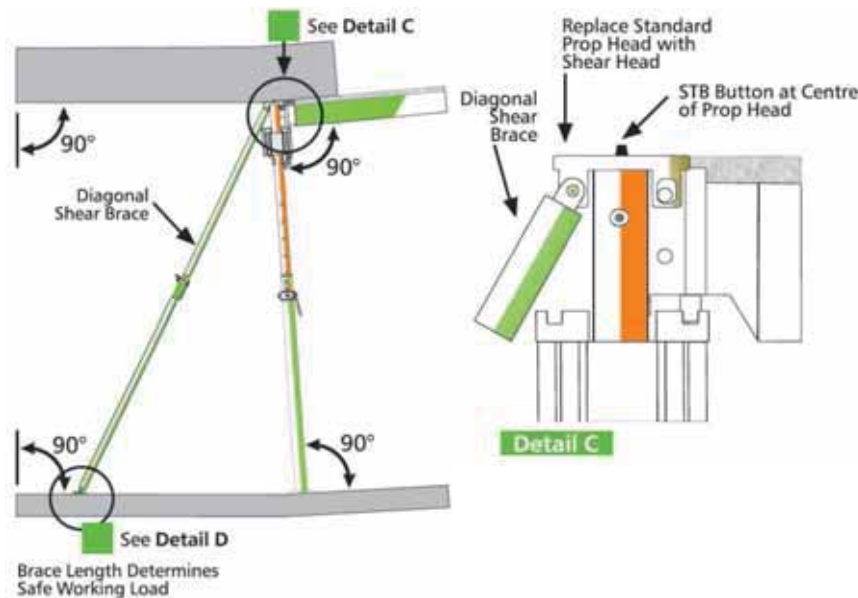
- 1 Erect shoring towers using TABLA Panel spacing
- 2 Remove Head Plate from Pioneer Head Assembly or TABLA Prop
- 3 Connect Pioneer Head Assembly or TABLA Prop to top of shoring frames
- 4 Drop TABLA Panels into position from above, snap in TABLA Prop Heads, then pour the floor
- 5 Once concrete reaches 2000 psi, and in accordance with ACI, strip TABLA Panels

Note: TABLA advise the use of a safe access system for this work.



Consult TABLA's Engineering Department for more information TABLA Pioneer.

TABLA Pioneer System

BUILD STRONG BUILD WITH QUALITY

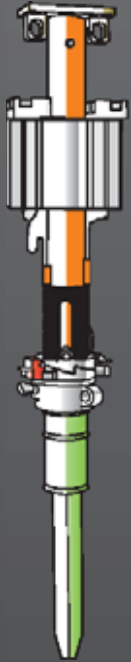

Detail 1

Pioneer Head Assembly

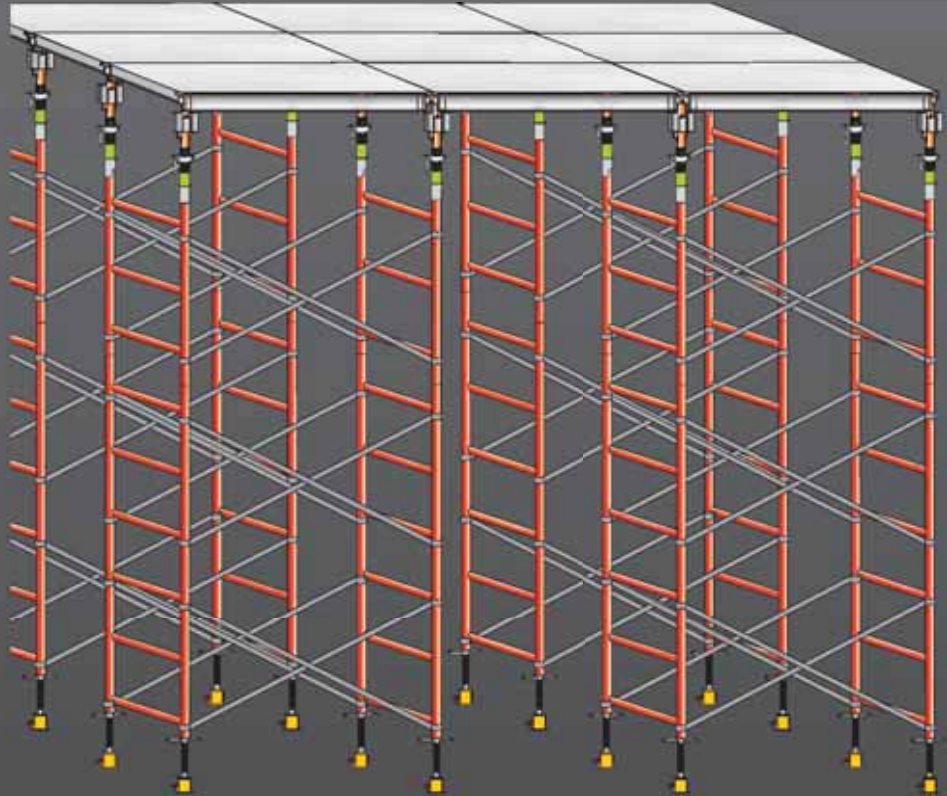

Shown with Pioneer Head Assembly (see Detail 1)

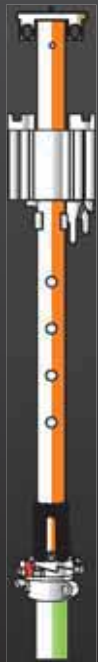

Detail 2

Tabla Prop

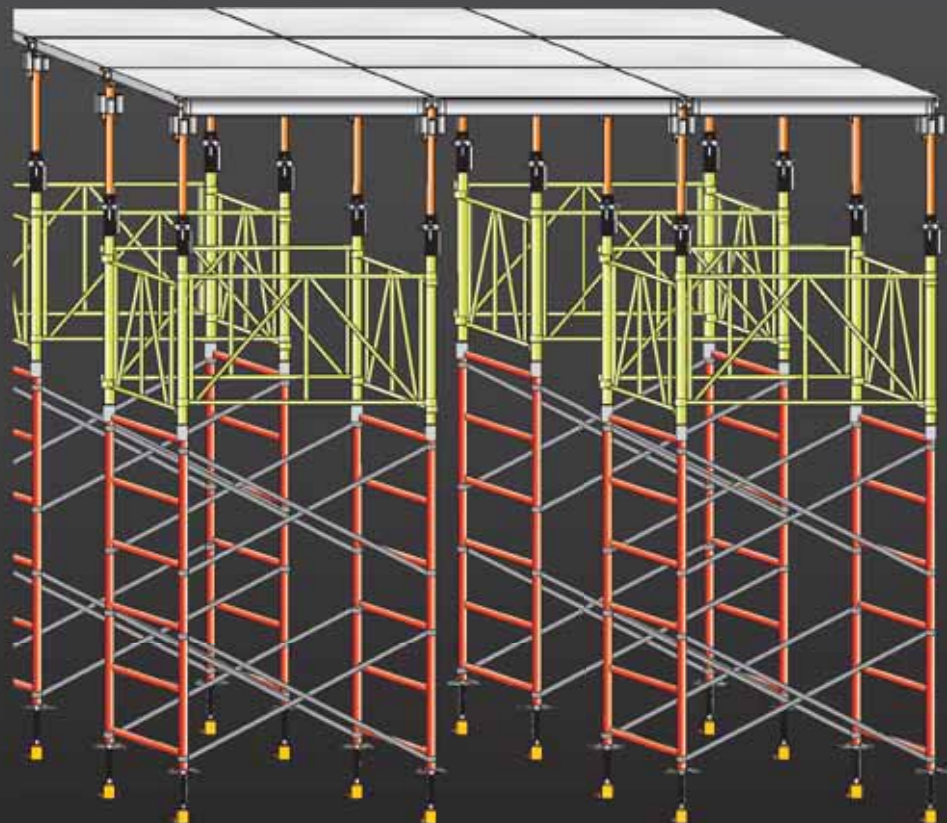

Shown with the Table Prop (see Detail 2)

Infill components



TABLA Infill Components

TABLA infill Components are designed to bridge between Panels or between Panels, walls and columns.

Construction workers are using Side and End Filler Beams along with the Telescopic Beam they are holding to infill around a column at a project in Biola.



Side Filler Beam



End Filler Beam

Side and End Filler Beams

Side and End Filler Beams allow 3/4" plywood to infill to the side of the Panel. The benefits of using Side and End Filler Beams are :

- Provide nailer strip for connecting 3/4" plywood;
- Eliminates notching of plywood around Post Shore Heads;
- Eliminates eccentric loading on Prop;
- Colour coded* for quick identification between Side and End Rails of Panels - simply match colours during erection.

Place the Filler Beam into the Prop Cup and secure it using the TABLA Gravity Lock through accessory holes of the Panel and Filler Beam.



Gravity Lock

*Colours are reversed for metric sizes.

Telescopic Beams

Telescopic Beams

TABLA Telescopic Beams are light weight and have an excellent load capacity. They are designed to take Drop Heads and Infil Strips from 3'0"/914 to 10'0"/3050. Telescopic Beams connect directly to the Filler Beams. These Beams are equipped with a graduated Bearing Plate at each end. Each Bearing Plate consists of 5 gravity bearing seats in 1" increments. By using the lowest seat the TABLA Telescopic Beam forms a flush deck using $\frac{3}{4}$ " 19 mm plywood infill. Other levels are for change in slab thickness and Drop Heads.

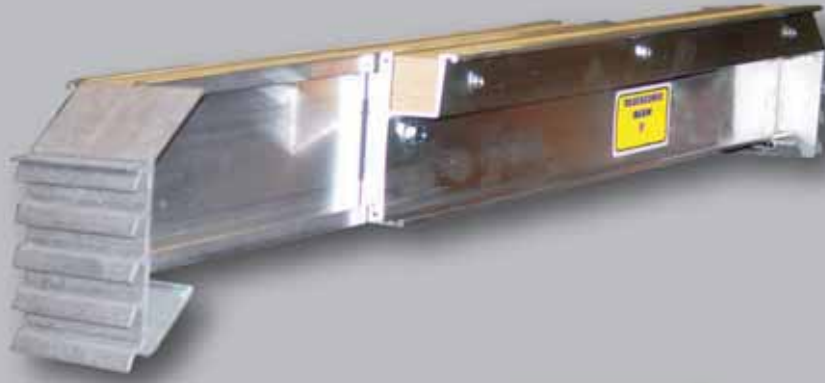

Telescopic Beams



Telescopic Beams

BUILD STRONG BUILD WITH QUALITY

For deeper drops of the Telescopic Beam use the Telescopic Beam Extension.



Beam Extension

Use Telescopic Beam Hanger to connect to wall or column ledger.



Beam Hanger

Supplemental Support

In cases where the load or the drawing requires for "supplemental support", the recommended procedure is as illustrated. At all times make sure that when installing the supplemental supports they do NOT lift the gravity seats out of the edge support.

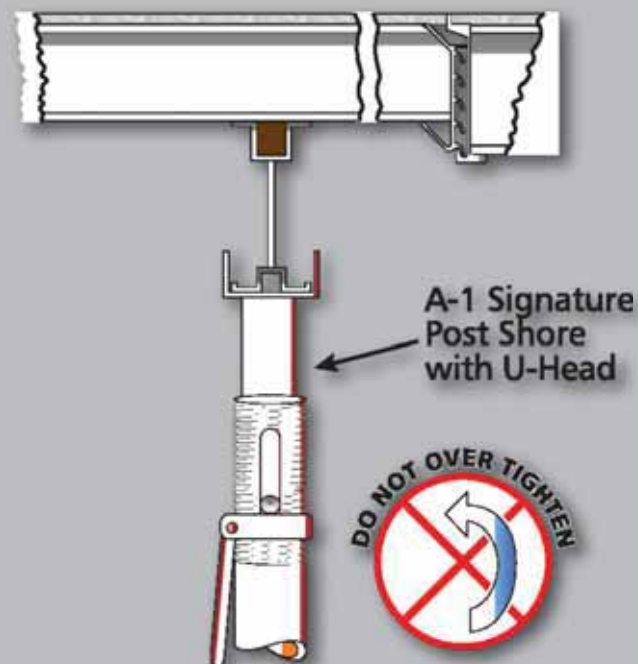

Telescopic Beam supported at mid-span with "U-Head" Post Shore.

Do not over tighten post shore & lift up formwork.
Carpentry formwork by Contractor.
Check drawings for exact details. Telescopic Beams may need supplemental supports.
Always refer to Engineering drawings for the Telescopic Beam spacing and supports.

Stripping of TABLA Panels Report

Ramon J. Cook, P. E.

913 Dimrock Drive
Phone: 210-659-0022

Schertz, Texas 78154
E-mail: ramoncookpe@sbcglobal.net

Stripping of TABLA Panels from under Green Concrete Reinforced Concrete or Post Tensioned Concrete / Pre-Tension

When it is desirable or required to strip (remove) TABLA Panels from under recently poured concrete, it is acceptable to do so under the following conditions.

- 1) The ambient temperature under the slab must be no less than 45 F (7 C) – naturally or artificially maintained.
- 2) The tested strength of a slab poured and cured cylinder must be at least 2,000 PSI.
- 3) The grid spacing (size / dimensions) must not exceed 8' x 4' panel / prop spacing (2,500mm x 1250mm).
- 4) The TABLA Prop head must not at this point be disengaged from the curing concrete slab, avoiding stripping shock.
- 5) Until the concrete cylinder strength exceeds 2,500 PSI, construction loads on the suspended slab must be limited to no more than 20 lbs per sq ft (9.0 kg) between the TABLA Props (Backprops) supporting this slab.
- 6) Continue to cure concrete in accordance with jobsite specifications.
- 7) Leave TABLA props undisturbed until contract specification concrete strength is gained.
- 8) This bulletin pertains only for use where TABLA System undisturbed BackPropping is employed, and is not intended to be interpreted as applying to the jobsite as a whole.

This bulletin is a synopsis of an overview by engineer Ramon Cook P.Eng. If more information is required contact Art Magee, TABLA Engineering Department (TED) at TED@TablaShoring.com here to arrange consultation with Mr. Cook.



2006 P.E. Licenses: Delaware = 6119; District of Colombia = 7543; Maryland = 12521; Virginia = 13351; Georgia = 17268; Texas = 22830; New Jersey = 28480

Ramon J. Cook, P. E.

913 Dimrock Drive
Phone: 210-659-0022

Schertz, Texas 78154
E-mail: ramoncookpe@sbcglobal.net

18 April 2006

Mr Paul Gillespie, President
Gillespie Practical Technologies, Inc
Toronto, Ontario Canada

Re: TABLA Reshore Safety Factor

Safety Factors of shoring: supports for concrete forms under unstable wet weights; have long been required to adhere to minimum limits of 2.5/1.0 for framed shoring and 3.0/1.0 for single post shoring. TABLA takes no exception to this rule.

TABLA standard post shore rating is 7,200 lbs each, when plumb, under braced panel arrays, and extended to 12'- 0" max height, with 3/1 Factor of Safety on ultimate strength.

OSHA, ANSI A10.9, and ACI 347 are all silent on the subject of Safety Factors for RESHORES of dry weights. ACI 347.2R-05, Shoring/Reshoring of Concrete Multi-Story Buildings says "Where manufactured shores/reshores are used, the manufacturer's data should be consulted for safe working loads and other safety requirements of the shores/reshores and hardware." (Section 5.1.5, Adequacy of shoring/reshoring system)

GPT has chosen a safety factor for RESHORES of 1.7 based on the structures own design load factors. These are given in SEI/ASCE 37 as 1.2 for dead loads, 1.4 for all loads, and 1.6 for construction live loads. Dead load of TABLA shoring/reshoring system is so light in comparison to construction slab & superimposed construction forces being carried (which equal to "live loads", as far as reshoring is concerned) that the total factor = 1.7 was chosen by GPT as a legitimate load factor for practical design purposes and jobsite safety.

This is tenable because the reshores are standing on a braced surface: a completed slab is braced into its building structure, or it wouldn't be able to support reshores! In addition, the slab above being propped is stable, also tied into its columns and walls, or it couldn't have been stripped of forms to be reshored. So, it only remains for the reshores to be stable at ceiling heights per ACI's spec: "manufacturers' data". TABLA post shores were tested per SSFI methods to obtain that verified strength-to-height data.

Respectfully submitted,

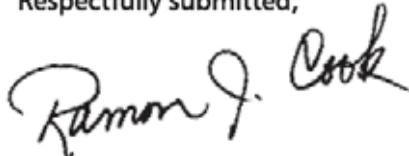

Ramon J. Cook, P. E.



2006 P.E. Licenses: Delaware = 6119; District of Colombia = 7543; Maryland = 12521;
Virginia = 13351; Georgia = 17268; Texas = 22830; New Jersey = 28480

Ramon J. Cook, P. E.

913 Dimrock Drive
Phone: 210-659-0022

Schertz, Texas 78154
E-mail: ramoncookpe@sbcglobal.net

TABLA Panel Strip Time Report

31 Mar 2006

Gillespie Practical Technology has invented a slab form and shore system which has a firm root in existing and traditional ACI documents.

The TABLA system combines

- 1.) **Shoring:** support of wet weight and placing loads; with
- 2.) **Reshoring:** support of curing or dry weight.

In ACI 347R-04 definition, stripping the panels out separately from their shoreposts equals the "Backshoring" method of floor construction. "Backshoring" is defined in 347's document as stripping out ONLY SMALL AREAS of form, and immediately placing reshores so "the slab does not deflect and carry its own weight" alone. Backshoring has been found by long practice as satisfying the need for form removal while maintaining immediate green slab support. Thus, structurally, the TABLA panel-removal method does not strip TABLA prop supports, while it does permit the Contractor to get out the panels alone.

With props in place, as-cast, no slab is allowed to deflect and transfer its own weight to beams and columns. Nor, is any beam on TABLA shoring allowed to transfer its own weight to columns and walls. Both are completely supported according to Code. Soffit areas are subject to curing spec's and top live load limits (20 psf, overall average, max), of course.

TABLA shoring patterns are the same for any slab thickness: 4 ft x 8 ft max. The concrete green strength needed before panel strip depends on concrete tensile capacity for post punching shear and "unreinforced bending (per tilt-up standard practice) rather than traditional compression strength. If compression strength is in the range of 2000 psi, and modulus of rupture (beam test) tensile strength in the range of 250 - 300 psi, then panels may be stripped. If these levels can't be guaranteed, the panels must stay in place until they are known and guaranteed.

At all times, Owner's specification minimum concrete compression strength stripping time in contract documents does apply to TABLA prop removal, however.

"Reshoring" is another process, totally separate from TABLA panel removal. TABLA props may be reshores, also, and often are. But, other reshoring methods are available, and are not germane to the subject of "getting out panels earlier than props".

Respectfully submitted,

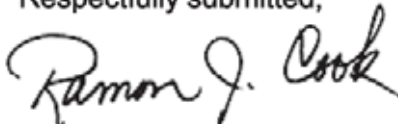

Ramon J. Cook, P. E.



2006 P.E. Licenses: Delaware = 6119; District of Colombia = 7543; Maryland = 12521;
Virginia = 13351; Georgia = 17268; Texas = 22830; New Jersey = 28480

Ramon J. Cook, P. E.

913 Dimrock Drive
Phone: 210-659-0022

Schertz, Texas 78154
E-mail: ramoncookpe@sbcglobal.net

TABLA Panel Strip Time Report

31 Mar 2006

Addendum & References:

Panel removal flexure considerations:

The distance at which "full flexure" deflection vs "shear-block" deflection takes place is in the span/depth range of 32 to 1. This means a "span" of 32 times thickness. Under an 8" slab, for example $32 \times 8" =$ about 21 feet, or 6.3 m is required before "flexure" as measured by "standard" calculation methods can occur. "Span" is figured from outside a support half-slab-depth, when supports are not theoretical knife-edges. TABLA max spans are only 11 to 1 span/depth ratio with panels removed, and flexural support widths are over 20% of clear spans. These geometries make TABLA supports far wider in ratio to span than simple "pin" or "knife-edge" bearings.

The TABLA prop system firmly supports slabs and beams in a direct, fool-proof pattern of exact placement and test-proven strength, during pour, during cure, and during reshore conditions. No reports of premature green-cracking of slabs after panel removal have been received from the many jobs this system has supported, when proper curing of that green concrete has been applied.

In short, TABLA props hold up green slabs with full-contact support at every shore head before, during, and after panel removal. TABLA props do it without drop-head shock, without delay in reshore placing, without error in reshore location, and without variations in plumb and preload...

Many Specifications haven't quite caught up with this new TABLA system.

References:

1. ACI 347 – 04, Section 3.5.1, Shoring;
Section 3.7.2.1, Removal of forms & supports;
Section 3.8.3, Other methods (backshoring)
2. ACI SP-4 7th Ed, Section 6, P35, Shoring design, "Other Patented Shoring Devices"
3. op cit: P35, and "Multistory Work", particularly the recommendation for removal of ALL forms & shores at 70% f_c specified minimum 28-day concrete ultimate strength. (Note: This does NOT mean removal of panels, leaving props in place, the TABLA Method)
4. op cit: P35, Table 6-9B, "obtain project-specific age-strength data for the mix and job conditions with which they are working"
5. op cit: Section 6, P37, Table 6-4A

Assessment of Minimum Cube Strength for Striking TABLA Forms



3rd April 2008

Paul Gillespie CEO
Tabla Shoring Systems
1541 Hurontario Street
Mississauga,
Ontario, Canada L5G 3H7

Galwally Lodge
4 Saintfield Road
BELFAST
BT8 6AA

Tel: 028 9064 4655

Fax: 028 9064 4744

Email: info@mcfni.co.uk

consult@ppf.co.uk

Dear Mr Gillespie

Assessment of Minimum Cube Strength for Striking Tabla Forms

Further to our discussion we have examined limiting factors in the performance of a 200mm thick concrete slab under the following conditions (a) supported on a 2.4m x 1.2m Shore Grid, (b) assumed to contain the minimum area of tensile reinforcement allowable under the design code and (c) subject to a construction loading of 2.5KN/sq.m (~ 50 lbs/ft²).

Three conditions were checked for lower-bound slab capacity, based on a shore-head plate size nominally 150mm x 80mm on plan and using conservative analysis and design in accordance with BS8110

- 1 Capacity based on flexural resistance of steel in tension.
- 2 Capacity based on flexural resistance of concrete in compression.
- 3 Capacity based on shear resistance of concrete.

Of these, punching shear, during the early low-strength phase of the curing concrete, is the limiting condition and based on our calculations the concrete strength, below which punching shear failure is critical, is around 5.0N/mm² (750 psi). Above this strength, punching shear resistance rapidly improves and the slabs lower-bound capacity switches to being governed by the minimum area of tensile reinforcement, which provides more than sufficient capacity for load transfer the shore heads.

However, in arriving at a suitable minimum strength at which the Tabla panels can be struck while leaving the shore prop undisturbed, account needs to be taken of the dynamics at the instant of load transfer during the striking operation and of uncertainty due to the fact that very early strength is not necessarily consistent throughout in a large area of slab.

As such we would suggest that 13.0N/mm² (1950 psi) is a safe and satisfactory strength at which the Tabla forms can be struck under normal temperate conditions. It could in our view be less, where ambient conditions are conducive and where more certainty with regard to the quality of site and mix design control is qualified and in evidence, but under no circumstances should the cube strength be less than 10.0N/mm² (1500psi).

We trust that this is helpful and should you require any further comment please do not hesitate to contact us.

Yours sincerely

Felix James Magee
On behalf of MCF Consulting

E:\MCF\Drawings\2008\100306_Gilgassia\Industrial\Construction\Detail\StrikingForms\100306_04_08.doc



Partners: Felix Magee Sidney Cranston Peter Scott
Consultant: Peter Fitzpatrick

Magee Cranston Fitzpatrick

Consulting Civil and Structural Engineers
Incorporating Fitzpatrick Consulting (NI) Limited



TABLA System Components



AL DHABI SCAFFOLDING & FORMWORK LLC

BUILD STRONG BUILD WITH QUALITY





Panels, Props and ADT in use at a construction site in Washington.



Russian Plywood Panels

Code	Component	ft
P42	Panel	4x2
P62	Panel	6x2
P82	Panel	8x2
P44	Panel	4x4
P64	Panel	6x4
P84	Panel	8x4



Russian Plywood Metric Panels

Code	Component	mm
P126	Panel	1200x600
P186	Panel	1800x600
P246	Panel	2400x600
P1212	Panel	1200x1200
P1812	Panel	1800x1200
P2412	Panel	2400x1200



TP64R

Russian Plywood Transition Panels

Code	Component	ft
TP44	Transition Panel	4x4
TP84	Transition Panel	8x4
P246	Transition Panel Left Hand	6x4
P1212	Transition Panel Right Hand	6x4



TP1812R

Russian Plywood Transition Metric Panels

Code	Component	mm
TP1212	Transition Panel	1200x600
TP2412	Transition Panel	2400x1200
TP1812L	Transition Panel Left Hand	1800x1200
TP1812R	Transition Panel Right Hand	1800x1200

Props

Code	Component	ft	mm
P10	Prop	0'10"	3124
P12	Prop	0'12"	3658
PE	Prop Extension	6'4"	1372
PE	Prop Extension	6'2"	762

Pioneer

Code	Component
PH	Pioneer Hand

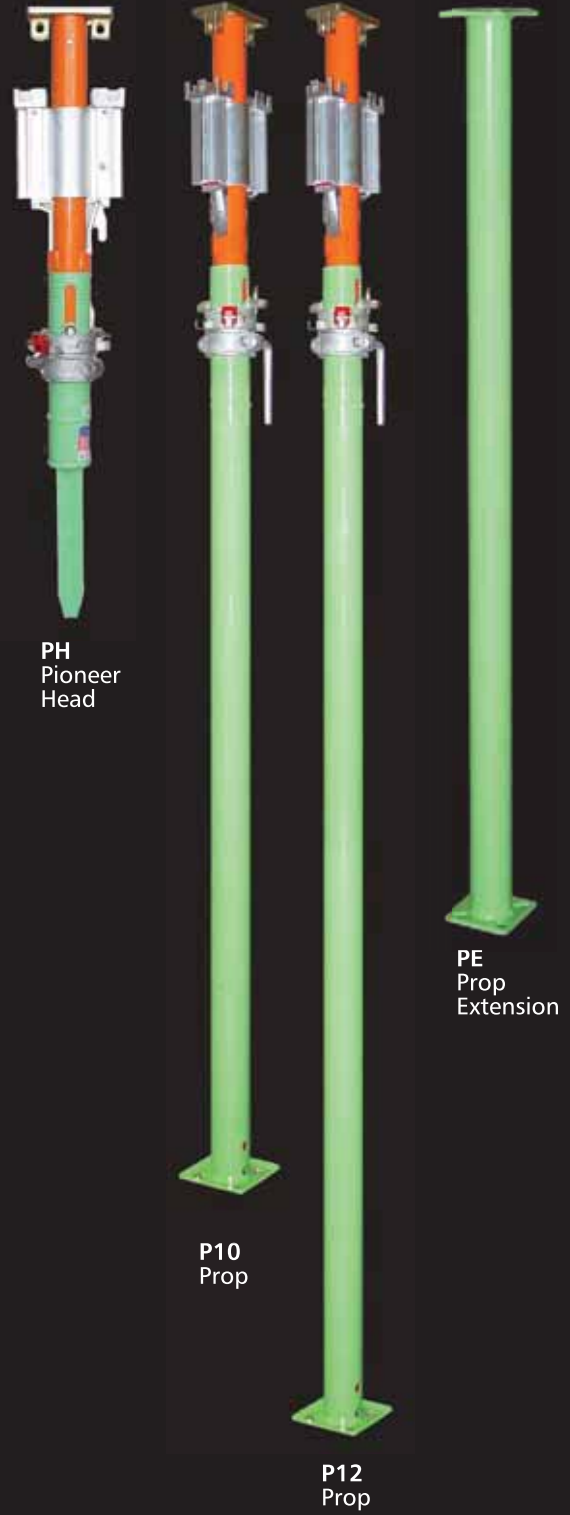

Beams and Hangers

Filler Beams

Code	Component	ft
EF2	End Filler	2
EF4	End Filler	4
SF4	Side Filler	4
SF6	Side Filler	6
SF8	Side Filler	8
FB(2x4)	Filler Bracket (2x4) 3 Way	
UGL	Universal Gravity Lock	

Metric Filler Beams

Code	Component	mm
EF6	End Filler	600
EF12	End Filler	1200
SF12	Side Filler	1200
SF18	Side Filler	1800
SF24	Side Filler	2400
FB(2x4)M	Filler Bracket (2x4) 3 Way	
UGL	Universal Gravity Lock	

Telescopic Beams

Code	Component	ft
TSB3	Telescopic Beam	3
TSB5	Telescopic Beam	5
TSB10	Telescopic Beam	10

Metric Telescopic Beams

Code	Component	mm
TSB3	Telescopic Beam	914
TSB5	Telescopic Beam	1524
TSB10	Telescopic Beam	3048

Swivel Telescopic Beams

Code	Component	ft
TSB3S	Swivel Telescopic Beam	3
TSB5S	Swivel Telescopic Beam	5
TSB10S	Swivel Telescopic Beam	10

Metric Swivel Telescopic Beams

Code	Component	mm
TSB3S	Swivel Telescopic Beam	914
TSB5S	Swivel Telescopic Beam	1524
TSB10S	Swivel Telescopic Beam	3048

Telescopic Beam Hanger

Code	Component
TBH	Telescopic Beam Hanger

Metric Telescopic Beam Hanger

Code	Component
TBDE	Telescopic Beam Drop Extension

EF4
End Filler Beam



SF4
Side Filler Beam



EF12
Metric End Filler Beam



SF12
Metric Side Filler Beam



FB 2 x 4
Filler Bracket 2 x 4 3-way



UGL
Universal Gravity Lock



TSB5
Telescopic Beam



TSB5S
Swivel Telescopic Beam



TBH
Telescopic Beam Hanger



Cantilever, Guard Rail, Post and Gate Brace



CP
Cantilever Post



CPE
Cantilever Post Extension



EMS
Edge Mounting Shoe

Cantilever

Code	Component
CP	Cantilever Post
CPE	Cantilever Post Extension
EMS	Edge Mounting Shoe
SGR	Slab Grab
EPC	End Panel Connector
SPC	Side Panel Connector



SG
Slab Grab



EPC
End Panel Connector



SPC
Side Panel Connector



GRP
Guard Rail Post



GR4
Guard Rail Panel



GRPC
Guard Rail Post Connector

Guard Rail Panel and Post

Code	Component	ft
GRP	Guard Rail Post	4.5
GR4	Guard Rail Panel	4.0
GR6	Guard Rail Panel	6.0
G R8	Guard Rail Panel	8.0
GRPC	Guard Rail Prop Connector	

Metric Guard Rail Panel and Post

Code	Component	mm
GRP	Guard Rail Post	1372
GR12	Guard Rail Panel	1200
GR18	Guard Rail Panel	1800
GR24	Guard Rail Panel	2400
GRPC	Guard Rail Prop Connector	



GB4
Gate Brace

Gate Brace

Code	Component	ft
GB4	Gate Brace	4
GB6	Gate Brace	6
G B8	Gate Brace	8

Metric Gate Brace

Code	Component	mm
GB12	Gate Brace	1200
GB18	Gate Brace	1800
GB24	Gate Brace	2400

Stripping Bar and AD Tools

Tools

Code	Component
ADT	Assembly and Disassembly Tool
ADTLH	Long Handle for ADT
SB	Stripping Bar
ISB	Inertia Stripping Bar



SB
Stripping Bar



ISB
Inertia
Stripping Bar



ADT
Assembly
and Disassembly
Tool



BUILD STRONG, BUILD WITH QUALITY



ADX AluPanel Formwork System



ADX AluPanel System Product Identification



Wall Formwork

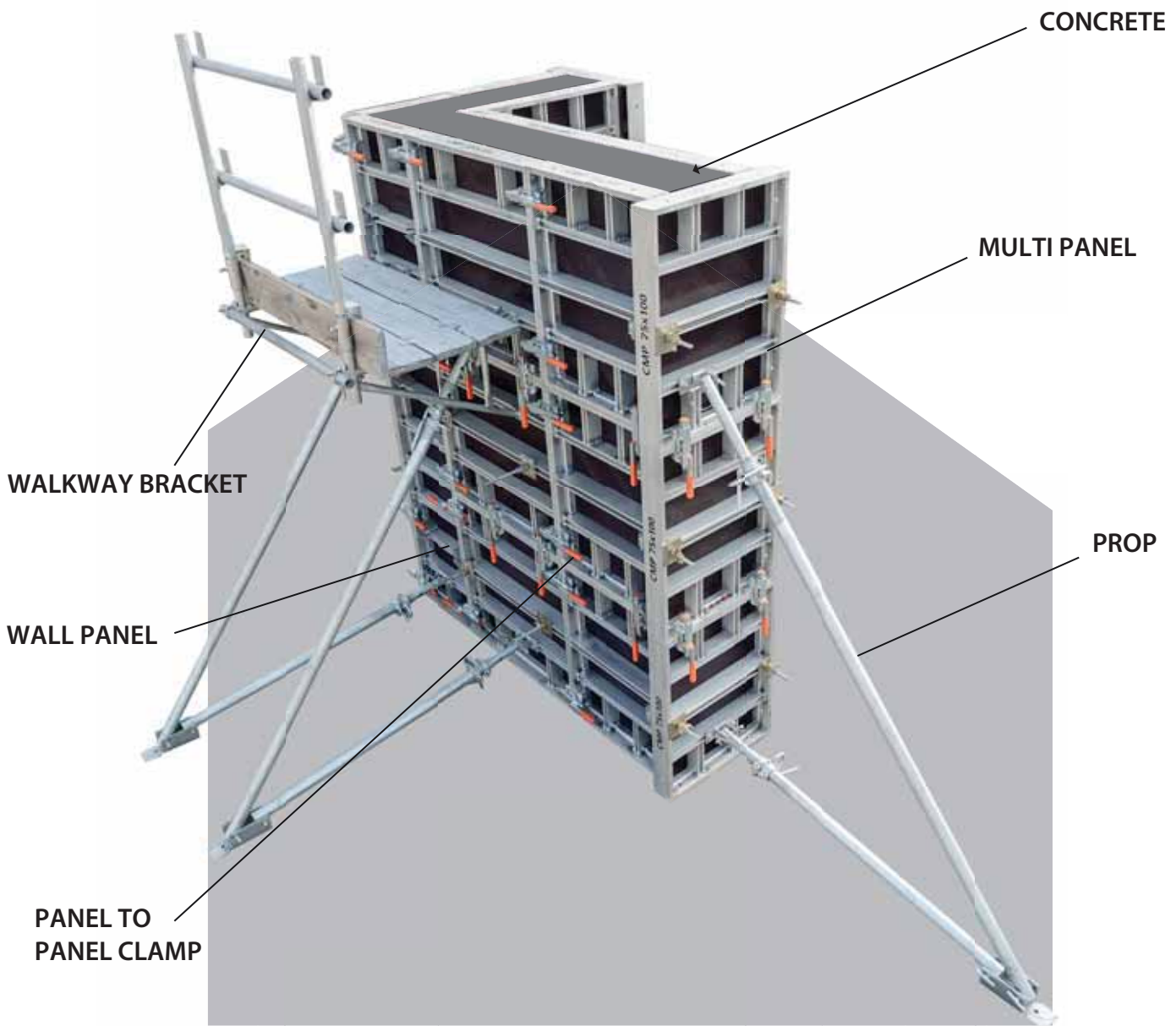

AD^X AluPanel System

Product Identification



WALL PANELS

Wall panels are the fastest way securing structure for concrete wall.

MATERIAL

Aluminium Alloy 6061-T6 / Equivalent

FINISH

Mill Finish

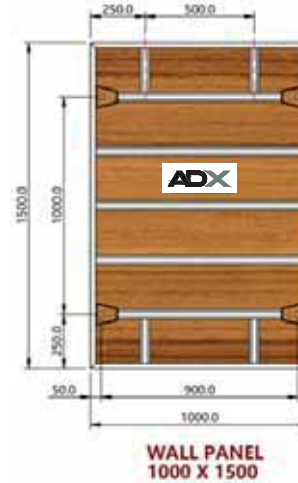
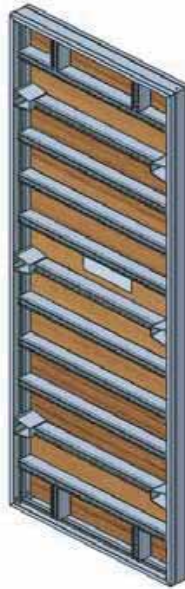
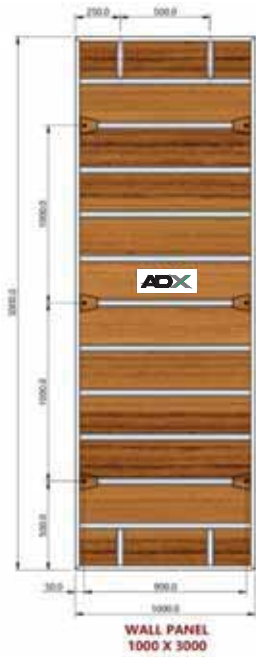

Item Code	Description	Width & Height	Weight
		MM	Kg
ADXW100300	Aluminium Wall Panel with Plywood	1000 x 3000	74.10
ADXW075300	Aluminium Wall Panel with Plywood	750 x 3000	56.20
ADXW060300	Aluminium Wall Panel with Plywood	600 x 3000	48.40
ADXW050300	Aluminium Wall Panel with Plywood	500 x 3000	43.30
ADXW045300	Aluminium Wall Panel with Plywood	450 x 3000	40.60
ADXW030300	Aluminium Wall Panel with Plywood	300 x 3000	32.50

Item Code	Description	Width & Height	Weight
		MM	Kg
ADXW100150	Aluminium Wall Panel with Plywood	1000 x 1500	40.90
ADXW075150	Aluminium Wall Panel with Plywood	750 x 1500	30.80
ADXW060150	Aluminium Wall Panel with Plywood	600 x 1500	26.50
ADXW050150	Aluminium Wall Panel with Plywood	500 x 1500	23.50
ADXW045150	Aluminium Wall Panel with Plywood	450 x 1500	22.20
ADXW030150	Aluminium Wall Panel with Plywood	300 x 1500	17.40
ADXW015150	Aluminium Wall Panel with Plywood	150 x 1500	13.70

ADX AluPanel System Product Identification

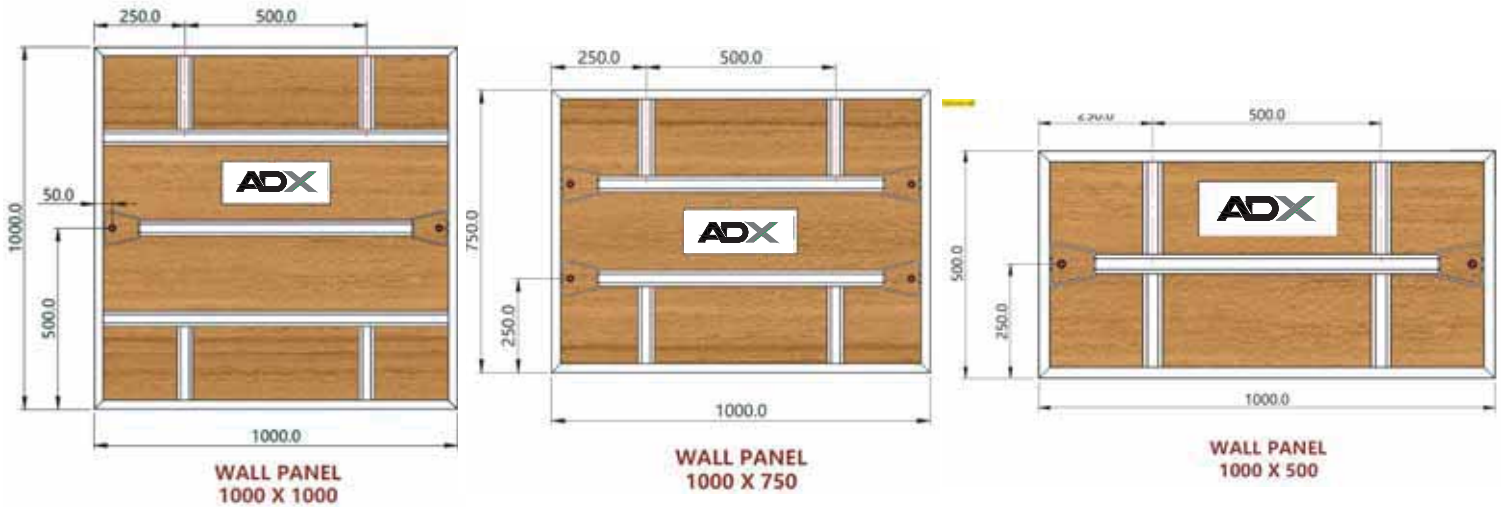

Wall Formwork

Item Code	Description	Width & Height	Weight
		MM	Kg
ADXW100100	ADX Aluminium Wall Panel with Plywood	1000 x 1000	30.60
ADXW075100	ADX Aluminium Wall Panel with Plywood	750 x 1000	22.90
ADXW060100	ADX Aluminium Wall Panel with Plywood	600 x 1000	19.30
ADXW050100	ADX Aluminium Wall Panel with Plywood	500 x 1000	17.30
ADXW045100	ADX Aluminium Wall Panel with Plywood	450 x 1000	16.40
ADXW030100	ADX Aluminium Wall Panel with Plywood	300 x 1000	12.70
ADXW015100	ADX Aluminium Wall Panel with Plywood	150 x 1000	10.00

Item Code	Description	Width & Height	Weight
		MM	Kg
ADXW100075	ADX Aluminium Wall Panel with Plywood	1000 x 750	25.40
ADXW075075	ADX Aluminium Wall Panel with Plywood	750 x 750	19.10
ADXW060075	ADX Aluminium Wall Panel with Plywood	600 x 750	16.10
ADXW050075	ADX Aluminium Wall Panel with Plywood	500 x 750	14.50
ADXW045075	ADX Aluminium Wall Panel with Plywood	450 x 750	13.80
ADXW030075	ADX Aluminium Wall Panel with Plywood	300 x 750	10.70
ADXW015075	ADX Aluminium Wall Panel with Plywood	150 x 750	8.00

Item Code	Description	Width & Height	Weight
		MM	Kg
ADXW100050	ADX Aluminium Wall Panel with Plywood	1000 x 500	18.50
ADXW075050	ADX Aluminium Wall Panel with Plywood	750 x 500	13.70
ADXW060050	ADX Aluminium Wall Panel with Plywood	600 x 500	11.40
ADXW050050	ADX Aluminium Wall Panel with Plywood	500 x 500	10.20
ADXW045050	ADX Aluminium Wall Panel with Plywood	450 x 500	9.60
ADXW030050	ADX Aluminium Wall Panel with Plywood	300 x 500	7.20
ADXW015050	ADX Aluminium Wall Panel with Plywood	150 x 500	5.70

ADX AluPanel System Product Identification

MULTIPANELS

Multi panels are also known as Column panel, it can be used for walls & column.

Material: Aluminium Alloy 6061-T6 / Equivalent **Finish:** Mill Finish

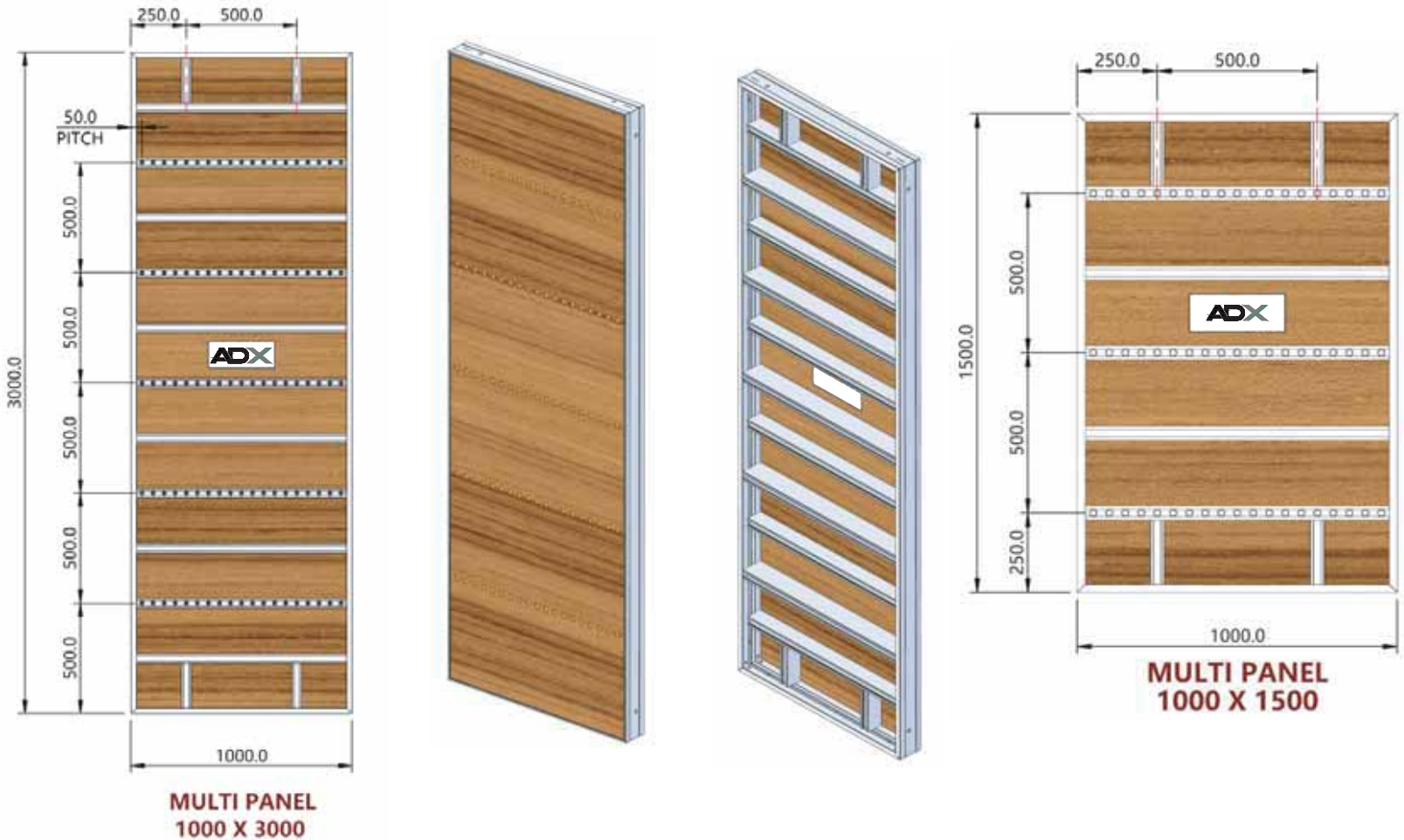

Item Code	Description	Width & Height	Weight
		MM	Kg
ADXM100300	ADX Aluminium Multi Panel with Plywood	1000 x 3000	83.40
ADXM100150	ADX Aluminium Multi Panel with Plywood	1000 x 1500	46.70
ADXM100100	ADX Aluminium Multi Panel with Plywood	1000 x 1000	31.90
ADXM100075	ADX Aluminium Multi Panel with Plywood	1000 x 750	27.20
ADXM100050	ADX Aluminium Multi Panel with Plywood	1000 x 500	19.80
ADXM075300	ADX Aluminium Multi Panel with Plywood	750 x 3000	62.10
ADXM075150	ADX Aluminium Multi Panel with Plywood	750 x 1500	34.50
ADXM075100	ADX Aluminium Multi Panel with Plywood	750 x 1000	23.40
ADXM075075	ADX Aluminium Multi Panel with Plywood	750 x 750	20.60
ADXM075050	ADX Aluminium Multi Panel with Plywood	750 x 500	14.60

ADX AluPanel System Product Identification

INTERNAL CORNER PANELS

Internal corner panels used to make internal joints between two walls or multi panels firmly with smooth continuous finish.

Material: Aluminium Alloy 6061-T6 / Equivalent **Finish:** Mill Finish

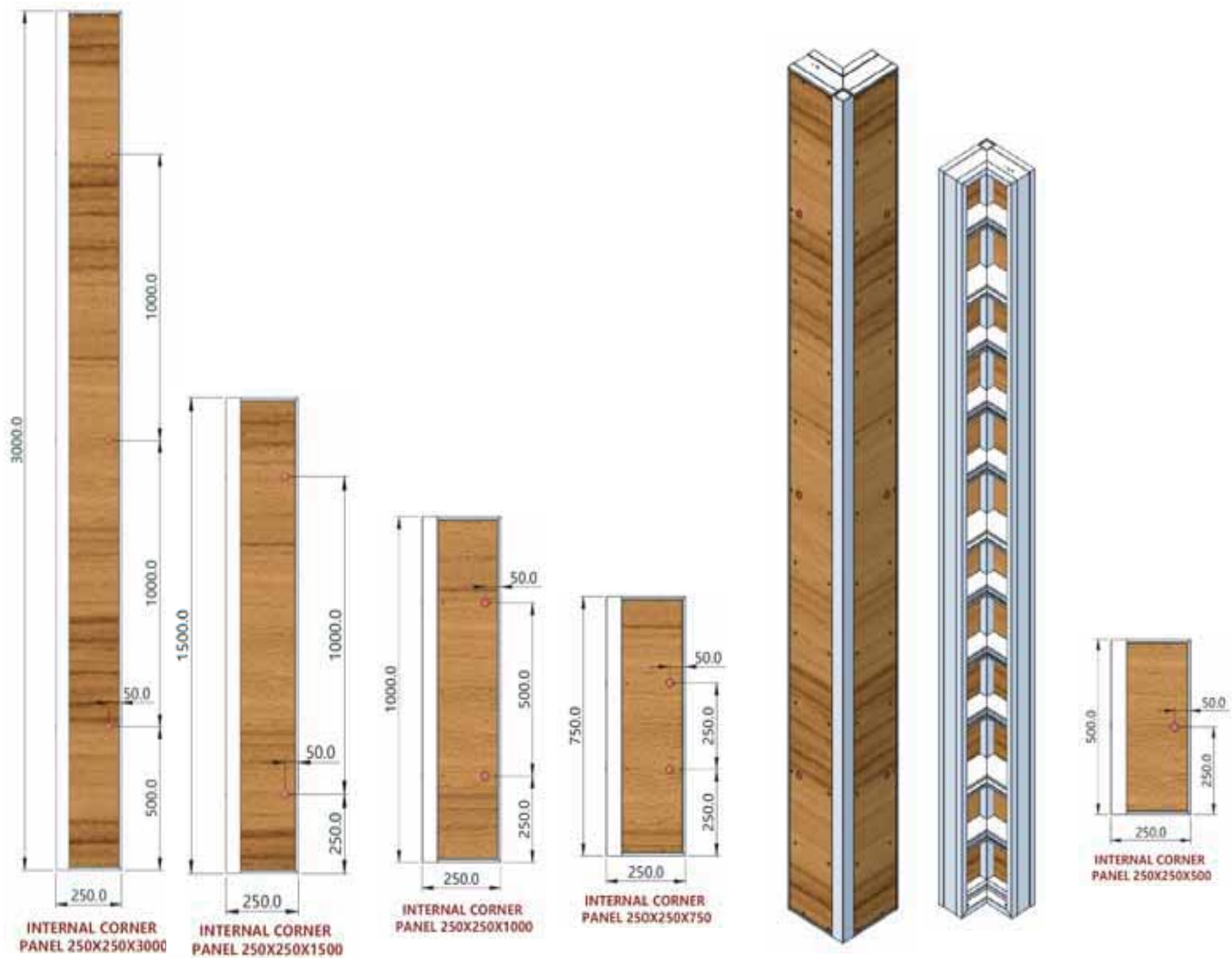

Wall Formwork

Item Code	Description	Width & Height MM	Weight Kg
ADXIC025300	ADX Internal Corner Panel with Plywood	250 x 250 x 3000	43.10
ADXIC025150	ADX Internal Corner Panel with Plywood	250 x 250 x 1500	22.90
ADXIC025100	ADX Internal Corner Panel with Plywood	250 x 250 x 1000	17.00
ADXIC025075	ADX Internal Corner Panel with Plywood	250 x 250 x 750	12.90
ADXIC025050	ADX Internal Corner Panel with Plywood	250 x 250 x 500	9.70

ADX AluPanel System

Product Identification

OUTSIDE CORNER PANELS

Outside corner panels used to make outer joints between two wall or multi panels firmly with smooth continuous finish.

MATERIAL

Aluminium Alloy 6061-T6 / Equivalent

FINISH

Mill Finish

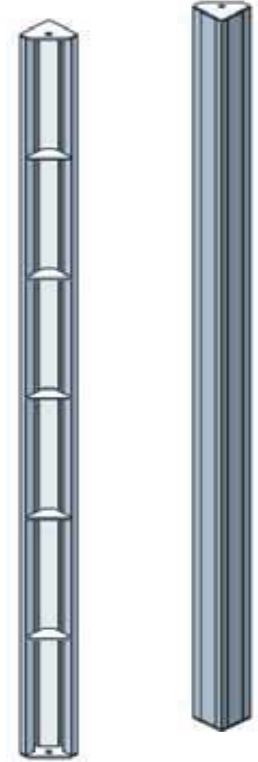

Item Code	Description	Width & Height MM	Weight Kg
ADXOC012300	ADX Outside Corner Panel	120 x 120 x 3000	19.10
ADXOC012150	ADX Outside Corner Panel	120 x 120 x 1500	9.70
ADXOC012100	ADX Outside Corner Panel	120 x 120 x 1000	6.80
ADXOC012075	ADX Outside Corner Panel	120 x 120 x 750	5.00
ADXOC012050	ADX Outside Corner Panel	120 x 120 x 500	3.40

SWING CORNER PANELS

Swing corner is used when there is requirement of concrete wall casting other than 90° (Perpendicular).

MATERIAL

Aluminium Alloy 6061-T6 / Equivalent

FINISH

Mill Finish

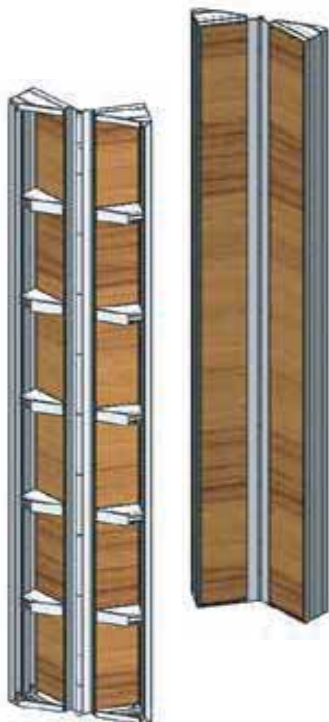

Item Code	Description	Width & Height MM	Weight Kg
ADXSC025300	ADX Swing Corner Panel with Plywood	250 x 250 x 3000	47.00
ADXSC025150	ADX Swing Corner Panel with Plywood	250 x 250 x 1500	25.00
ADXSC025100	ADX Swing Corner Panel with Plywood	250 x 250 x 1000	18.30

ADX AluPanel System Product Identification

WALKWAY BRACKET

Board brackets are used to extend the work platform closer to the structure.

MATERIAL

Structural Steel

FINISH

HDG

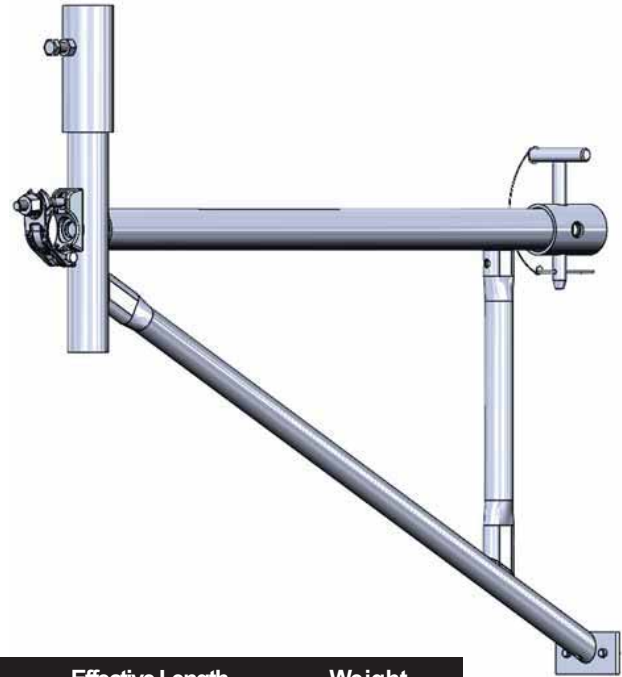

Wall Formwork

Item Code	Description	Effective Length	Weight
		MM	Kg
ADXWB	ADX Walkway Bracket(225 x 3 Planks) with 1 Pin	800	8.40

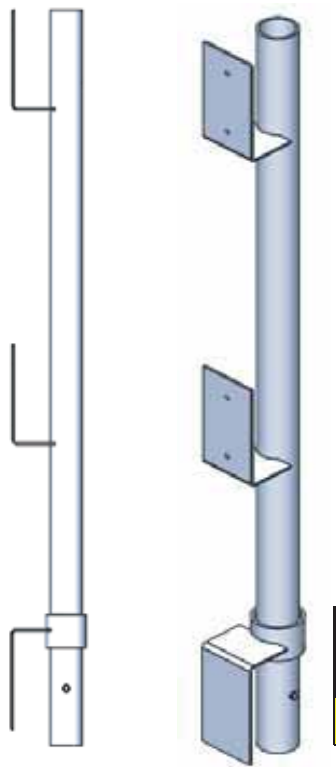

HAND RAILING POST 1.0 M

Hand rails are used to provide safety measures to the workers working on platform. This handrails is attached to the brackets.

MATERIAL

Structural Steel

FINISH

HDG

Item Code	Description	Effective Length	Weight
		MM	Kg
ADXHRP	ADX Hand Railing Post 1.0	1000	5.70

ADX AluPanel System Product Identification



BOTTOM BRACKET

Bottom brackets are used to hold and provide angular movement to the Raker Props at the bottom of the surface or slab.

MATERIAL

Structural Steel

FINISH

Electroplated

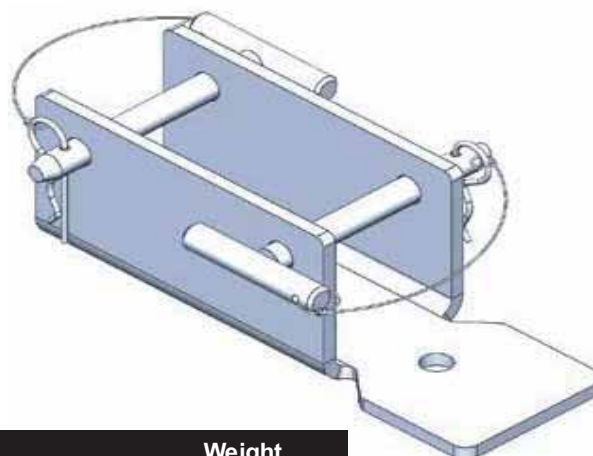

Item Code	Description	Weight Kg
ADX2BB	ADX Bottom Bracket with 2 Pins	4.80

TOP BRACKET

Top brackets are used to hold and provide angular movement to the Raker Props. And it is also used to hold walkways bracket using connecting pin To be used for 450mm wide and above panels.

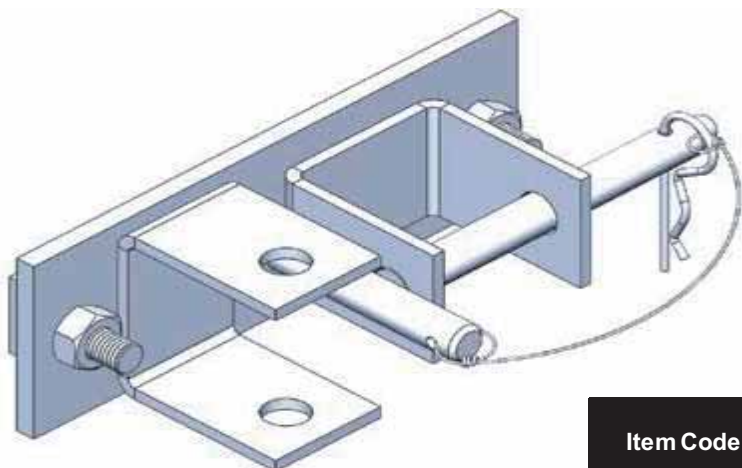

MATERIAL

Structural Steel

FINISH

Electroplated

Item Code	Description	Weight Kg
ADXTBD	ADX Top Bracket with Double U (1 Pin)	2.60

TOP BRACKET WITH SINGLE U

Top brackets are used to hold and provide angular movement to the Raker Props or Walkway bracket. To be used for 300mm wide & below panels

Material: Structural Steel **Finish:** HDG

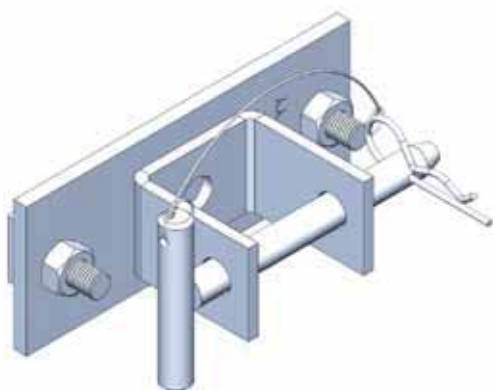

Item Code	Description	Weight Kg
ADXTBS	ADX Top Bracket with Single U (1 Pin)	2.00

ADX AluPanel System Product Identification

FOOTING BRACKET

Footing bracket are crucial in the case of casting of the single side wall, it can be anchor to the base, keeping wall panels intact to the base/flooring.

MATERIAL:
Structural Steel

FINISH:
HDG

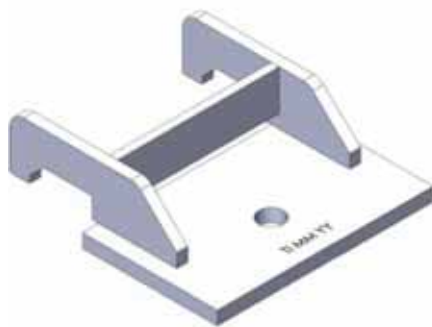

Wall Formwork

Item Code	Description	Weight Kg
ADXFB	ADX Footing Bracket	2.00

MULTI PANEL TIE CLAMP

This clamp is specially designed to use for clamping of wall panel with multi panel generally at the end of the wall.

MATERIAL
Structural Steel

FINISH
Electroplated

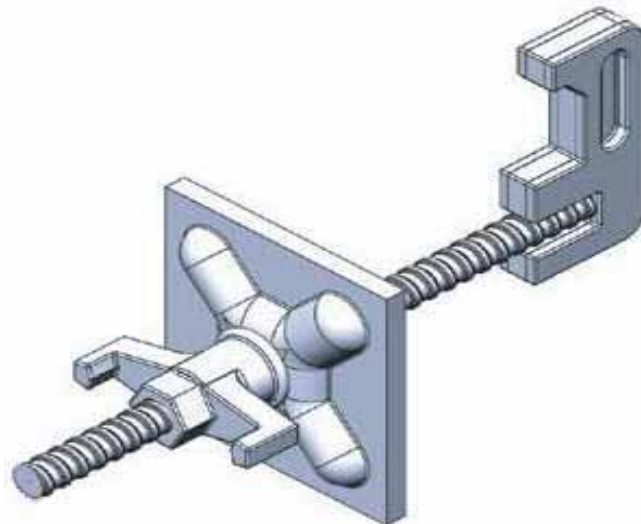

Item Code	Description	Weight Kg
ADXMPTC	ADX Multi Panel Tie Clamp	3.60

ADX AluPanel System Product Identification

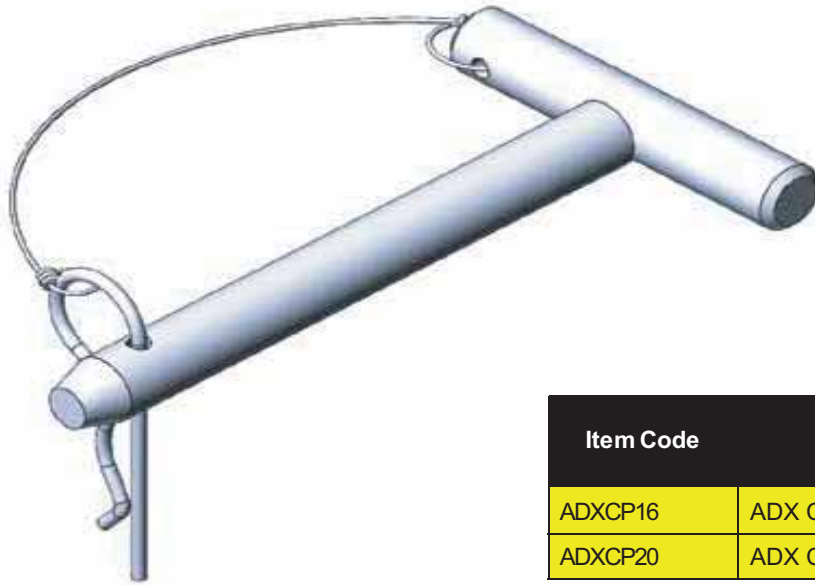

CONNECTING PIN

Connecting pins are used to connect props & brackets to the Wall panels.

MATERIAL

Structural Steel

FINISH

Electroplated

Item Code	Description	Weight Kg
ADXCP16	ADX Connecting Pin	0.40
ADXCP20	ADX Connecting Pin	0.50

RAKER PROP

Prop is use to rigidity to the ADX AluPanel System it is easily attached to the wall panels using Top & Bottom Brackets.

MATERIAL

Structural Steel

FINISH

HDG



RAKER PROP 6.0M M

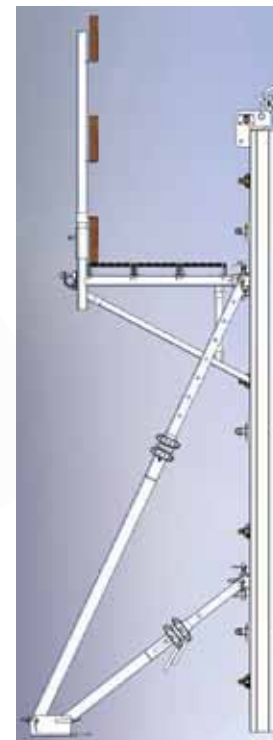

RAKER PROP 3.0M & 1.5M

Item Code	Description	Min. & Max. Extention MM	Weight Kg
ADXR45	ADX Raker Prop	2600 - 4500	24.90
APXRP26	ADX Raker Prop	1500 - 2600	15.00

UNIVERSAL WALER

Universal waler is used to connect two panels firmly. This waler can be fixed horizontally or vertically using Tie Rod.

Material: Structural Steel

Finish: HDG

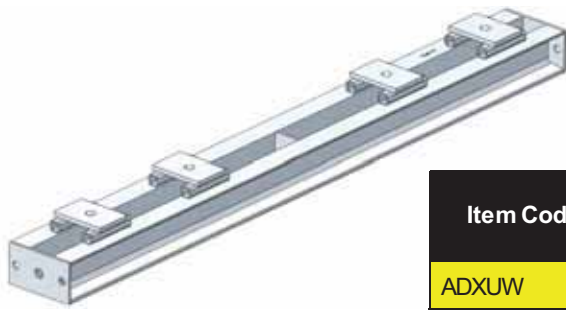

Item Code	Description	Weight Kg
ADXUW	ADX Universal Waler	21.40

UNIVERSAL WALER TIE CLAMP

Universal waler Tie clamp is used to clamp Panel and universal waler.

Material: Structural Steel

Finish: Electroplated

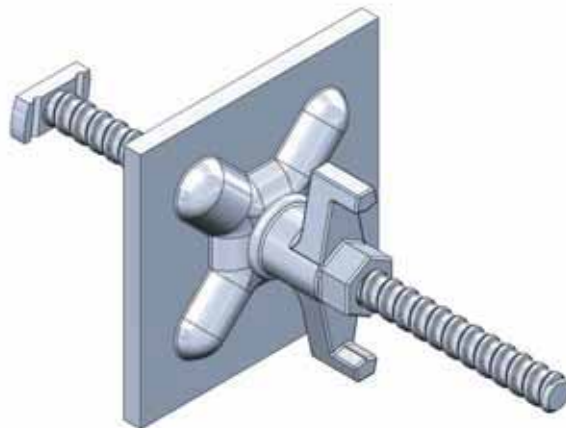

Item Code	Description	Weight Kg
ADXUWTC	ADX Universal Waler Tie Clamp	2.50

ADX AluPanel System Product Identification

HINGE WALERS

Hinge waler is special purpose waler used to align panels at angular wall (concrete) structure.

MATERIAL

Structural Steel

FINISH

HDG

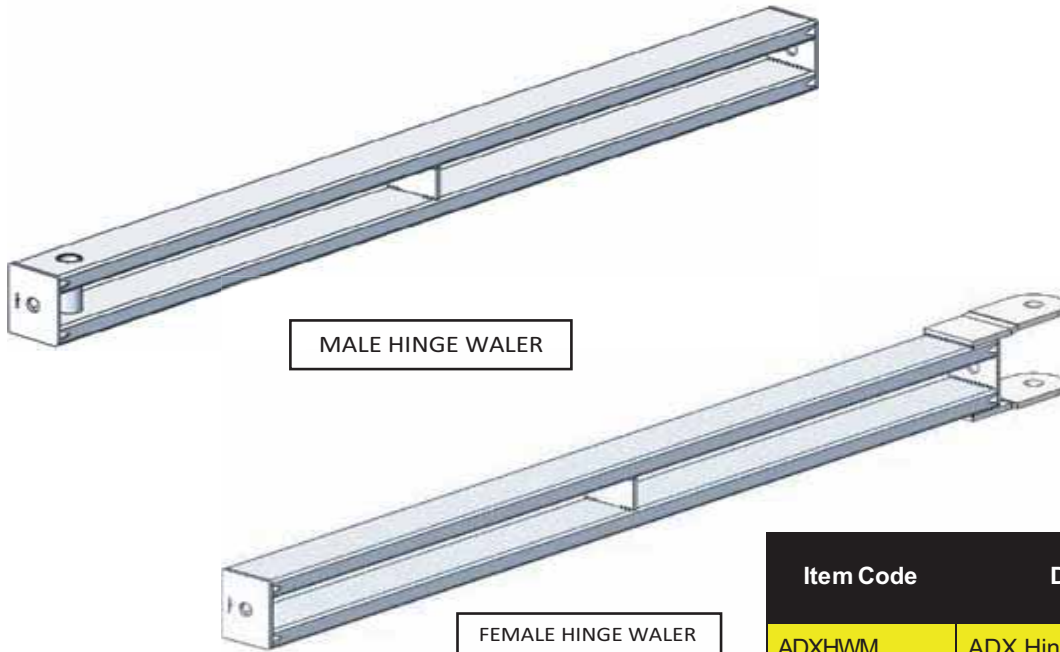

Item Code	Description	Weight Kg
ADXHWM	ADX Hinge Waler - Male	11.90
ADXHWF	ADX Hinge Waler - Female	13.30

350MM WIDE STEEL LADDER

Steel scaffold ladders are used in conjunction with ladder brackets so that workers can access the elevated work platforms safely.

MATERIAL

Structural Steel

FINISH

HDG

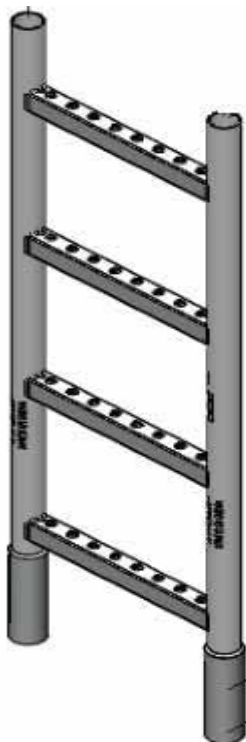

Item Code	Description	Height MM	Weight Kg
ADXLW3AS	350mm Width Steel Ladder	1000	6.60
ADXLW10AS	350mm Width Steel Ladder	3000	18.40

ADX AluPanel System Product Identification

LADDER CONNECTOR

Ladder connector is used to connect ladder to the wall panels firmly.

MATERIAL

Structural Steel

FINISH

Electroplated

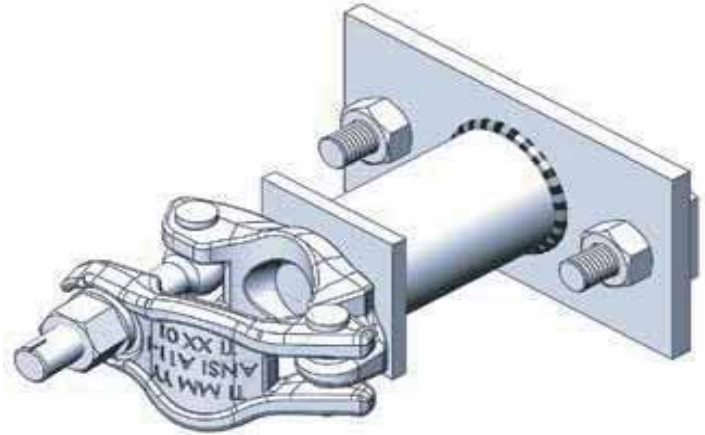

Wall Formwork

Item Code	Description	Weight Kg
ADXLC	ADX Ladder Connector	2.10

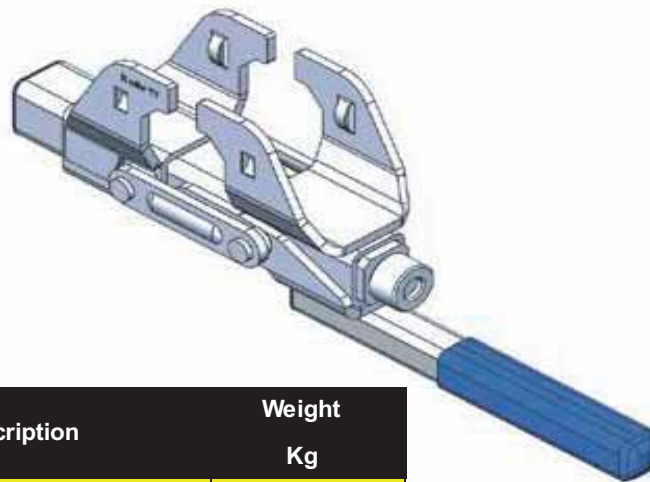

PANEL TO PANEL CLAMP

Panel to panel clamp is used to clamp two wall panels firmly.

MATERIAL

Structural Steel

FINISH

Electroplated

Item Code	Description	Weight Kg
ADXWPC	ADX Panel to Panel clamp	2.30

ADJUSTABLE PANEL CLAMP

Adjustable panel clamp is used to clamp wall panels when there is gap between the two panels which is filled (Adjusted) by timber.

MATERIAL

Structural Steel

FINISH

Electroplated



Item Code	Description	Max Opening Size MM	Weight Kg
ADXAPC30	ADX Adjustable Panel Clamp	300	4.50
ADXAPC15	ADX Adjustable Panel Clamp	150	4.00

ADX AluPanel System Product Identification

BULK HEAD TIE CLAMP

Bulk head tie clamp is used to clamp plywood at the end of the wall panels sides by keeping waler between plywood and base plate of the tie clamp.

MATERIAL

Structural Steel

FINISH

Electroplated

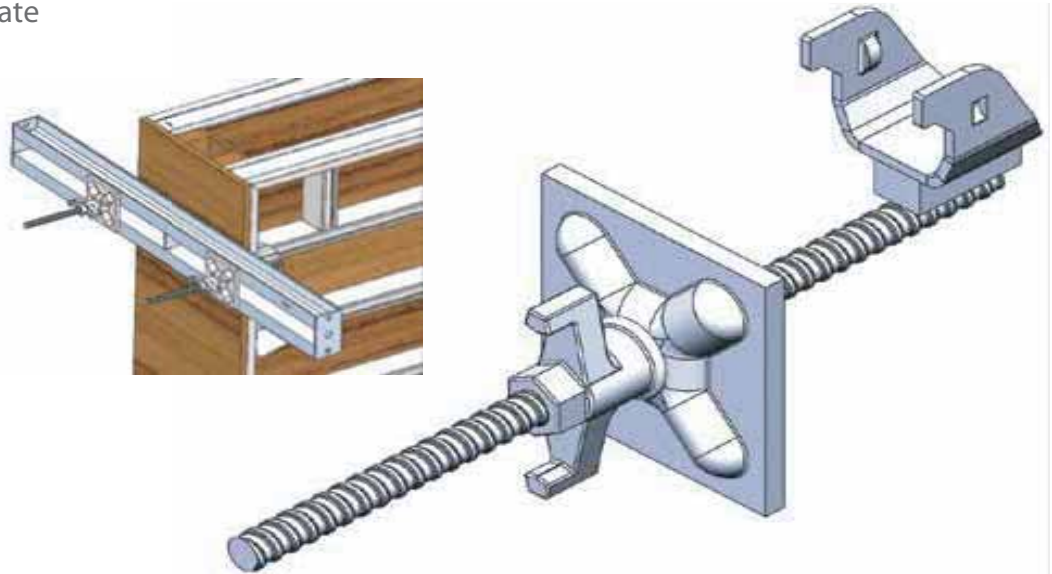

Item Code	Description	Weight Kg
ADXBHTC	ADX Bulk Head Tie Clamp	3.10

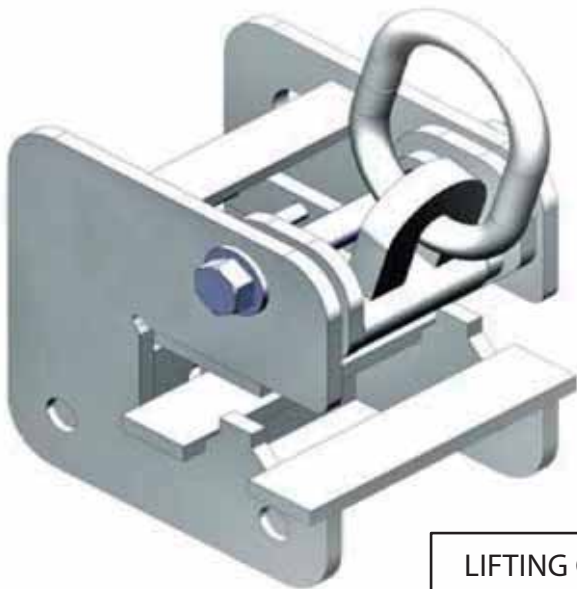

LIFTING CAPACITY = 15 kN

LIFTING BRACKET

Lifting Bracket is used to lift the pre-assembled Wall panels with accessories firmly.

MATERIAL

Structural Steel

FINISH

Electroplated

Item Code	Description	Weight Kg
ADXLB	ADX Lifting Bracket	8.30

ADX AluPanel System Product Identification

SYSTEM CHARACTERISTICS

External side of wall panels are welded with End Rail Profile, ribs are welded at every 25cm. The plywood is screwed to the wall panels.

END OR SIDE RAIL PANEL PROFILE

Two holes are allow Tie clamps to clamp panels with each other.

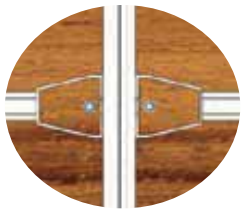

Wall Formwork

SYSTEM CHARACTERISTICS

Material	Aluminium Alloy 6061-T6
Sizes Range	Width- 300 to 1000 Height- 3000
	Width- 300 to 1000 Height- 1500
Finish	Mill
Permissible Allowance Fresh Concrete Pressure	60kN/m ²

PLYWOOD CHARACTERISTICS

12 mm Birch Plywood is lightweight, sturdy and economical to use in ADX AluPanel System. It provides smooth surface finish to the concrete after casting.

12 mm Birch Plywood

Thickness	12.0 mm
Coating- Filmfaced	220 GSM
Weight	8.2 kg/m ²
Thermal Conductivity	0.175 W/m ² K
Internal Composition	9 Layers (Birch)
External Protection	Phenolic Resin
Number of Re-uses	Min 50-60
Sides	Painted
Absorption of Humidity- Protected panel	Null
Absorption of Humidity- Cut panel	Elevated
Releases	Required
Repairs	With Feelers

ADX AluPanel System Product Identification

ASSEMBLY OF AluPanel WALLS

PRE ASSEMBLY:

Keep Wall panels on Wooden support block align them & clamp using Panel to Panel clamp as shown.

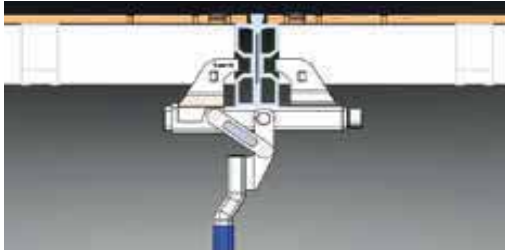

UNLOCK POSITION

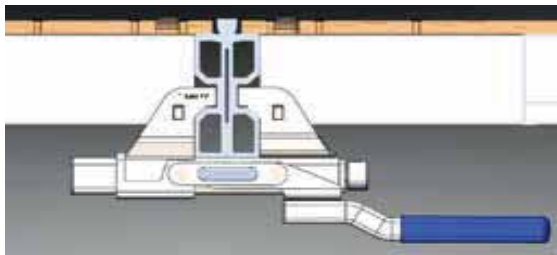

LOCK POSITION

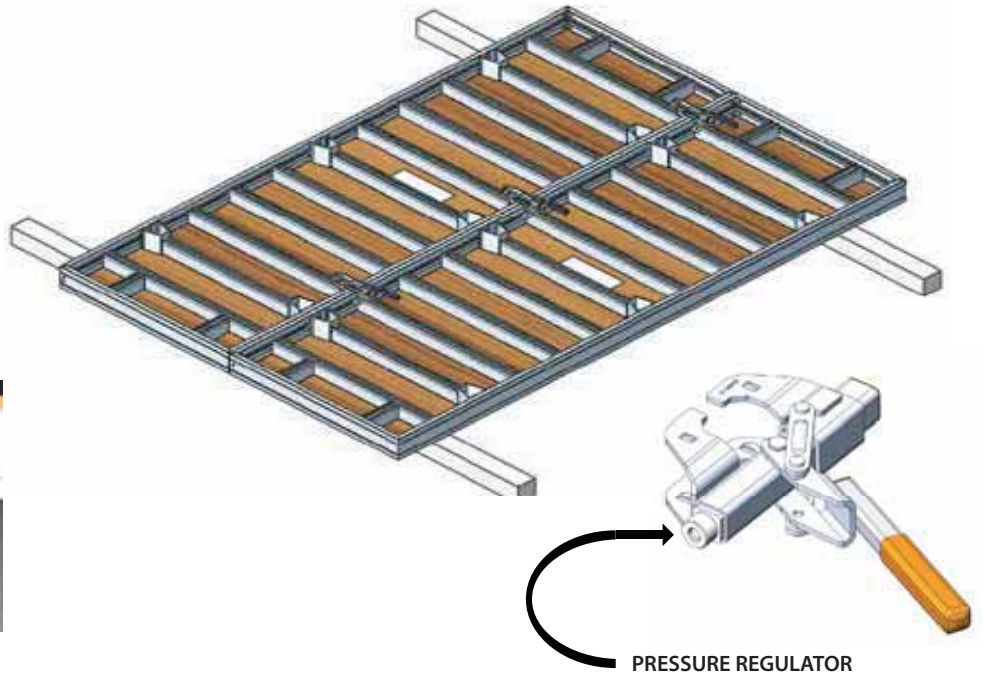

PRESSURE REGULATOR

- After clamping of panels with each other, assemble top bracket to the wall panels & attach walkway brackets using connecting pin.
- Props can be assemble to the top brackets as shown.
- After assembly of accessories to the wall panel carefully mount lifting clamp.

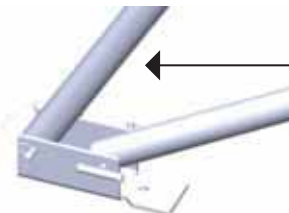

THE BOTTOM BRACKET IS ATTACHED TO THE PROPS USING CONNECTING PIN.

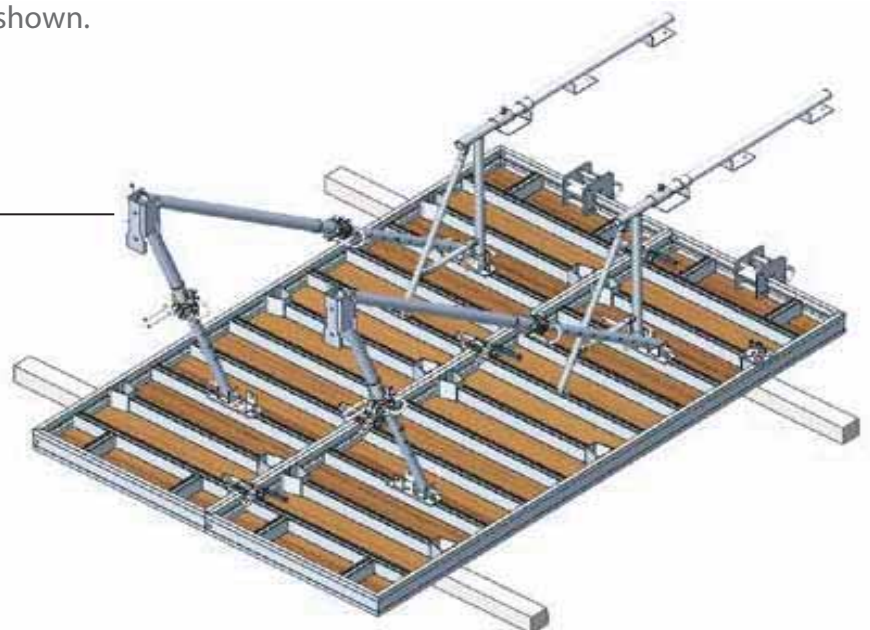

ADX AluPanel System Product Identification

After Checking of lifting clamp is safe to handle carefully lift the wall panel system and position it vertically as shown.

- 1) Lift the system.
- 2) Spray the release liquid.
- 3) Position the assemble wall panel system where it is going to get fixed.
- 4) Fix the props to the floor.
- 5) Insert the tie rod with plate & wing nut.
- 6) Keep the PVC spacer between the two wall panels, it ensures the distance & parallelism between them.
- 7) Add planks between the walkway brackets. Use wooden decks in guardrails.
- 8) Unhook the lifting clamp.

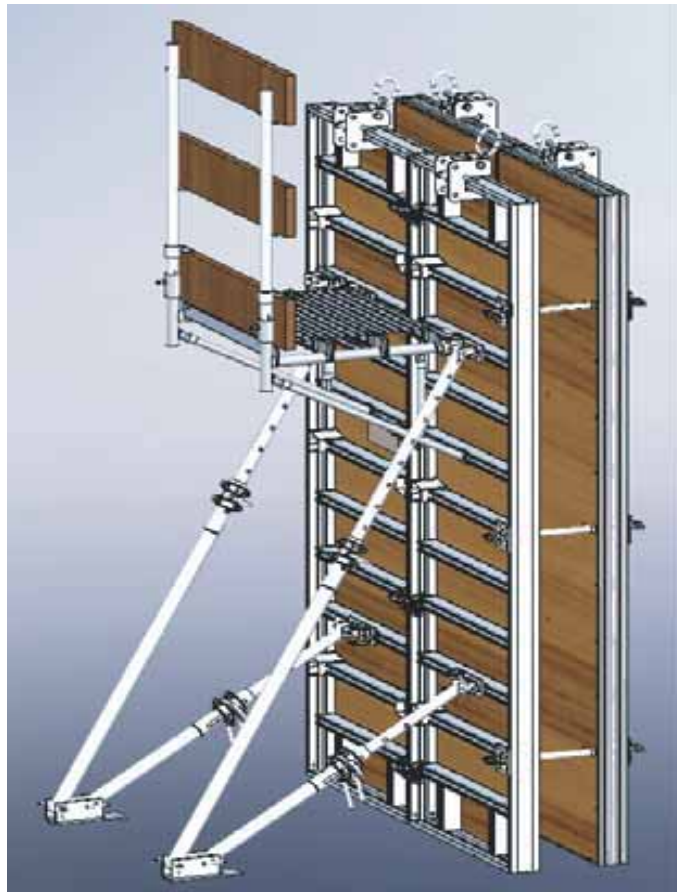
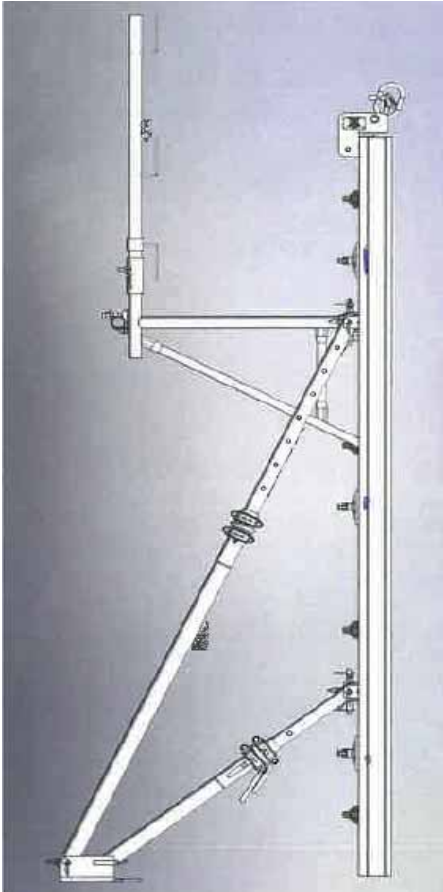

Repeat Same Procedure to assemble corresponding wall panels.
After assembly from both sides, pour concrete – Permissible pressure of fresh concrete 60 kN/m^2 .

DETAILING OF TIE ROD WITH PLATE

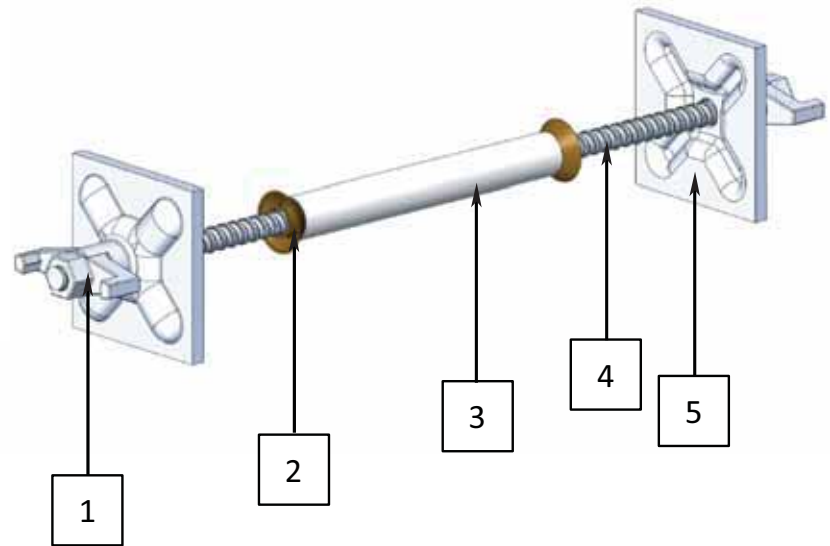

- 1 WING NUT
- 2 PLASTIC PLUGGING CAP
- 3 PLASTIC TUBE
- 4 Ø16.0MM TIE ROD
- 5 SUPPORT PLATE

ADX AluPanel System Product Identification

OPERATING INSTRUCTIONS FOR LIFTING BRACKET

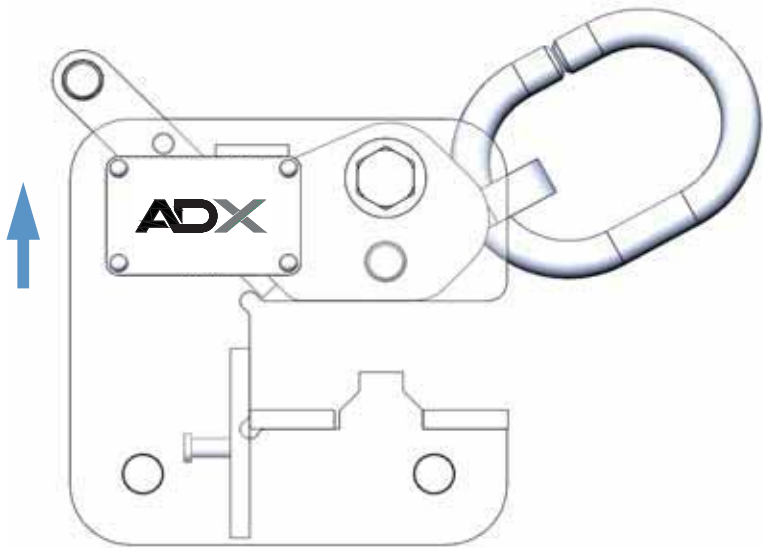

LIFT THE HANDLE UNTIL IT COMES TO A STOP.

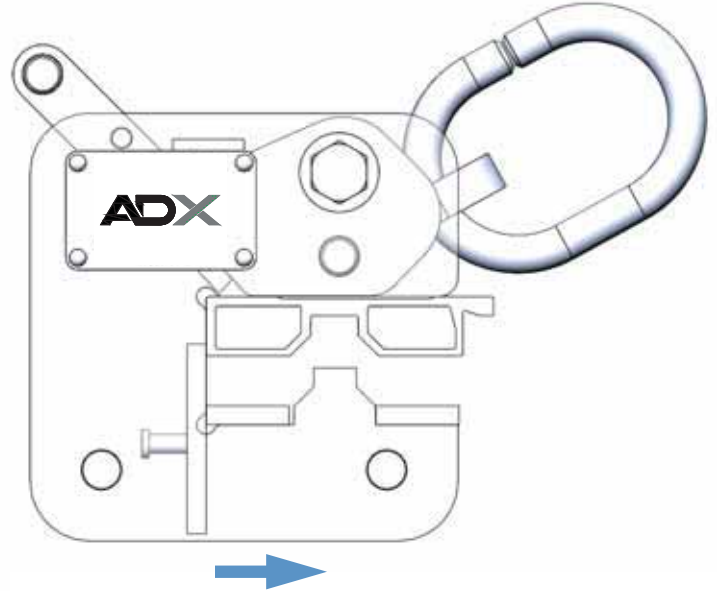

INSERT LIFTING BRACKET ON SECTION OF THE PANEL.

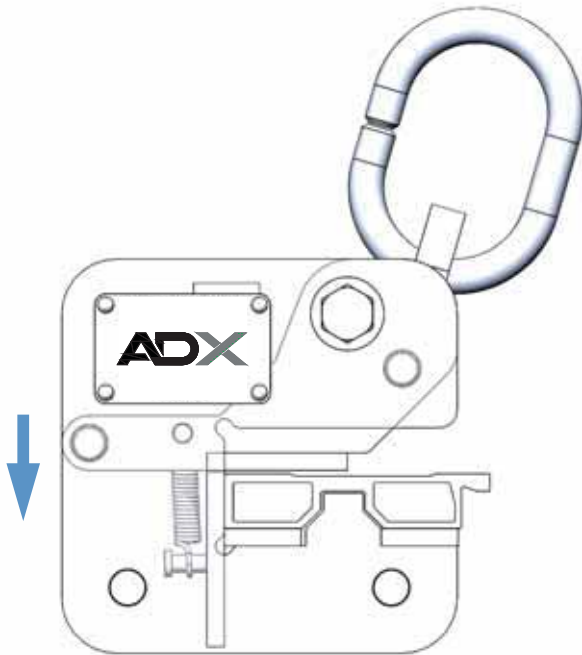

CLOSE THE HANDLE UNTIL IT COMES TO A STOP.

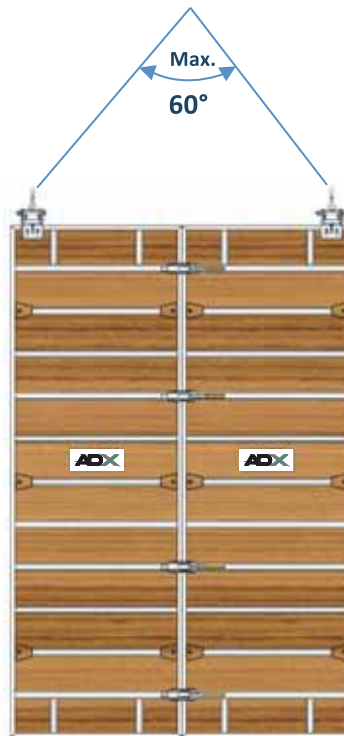

The spreading angle between the ropes of the lifting bracket should not exceed more than 60° as shown.



Maximum load on lifting bracket should not exceed more than 1500 kg. (15KN)

AD_X AluPanel System Product Identification

HIGH WALLS

When there is requirement of more than three meters walls, the waler & clamps are used to connect two panels vertically, this ensures alignment of panels and transmit the anchoring force the panels.

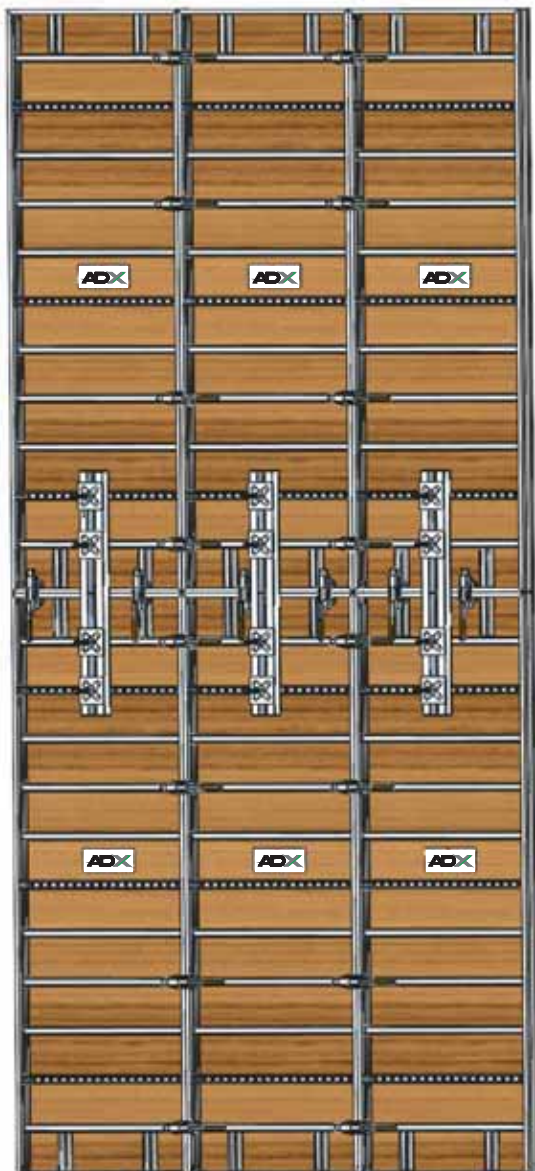

UNIVERSAL WALER
TIE CLAMP

UNIVERSAL WALER

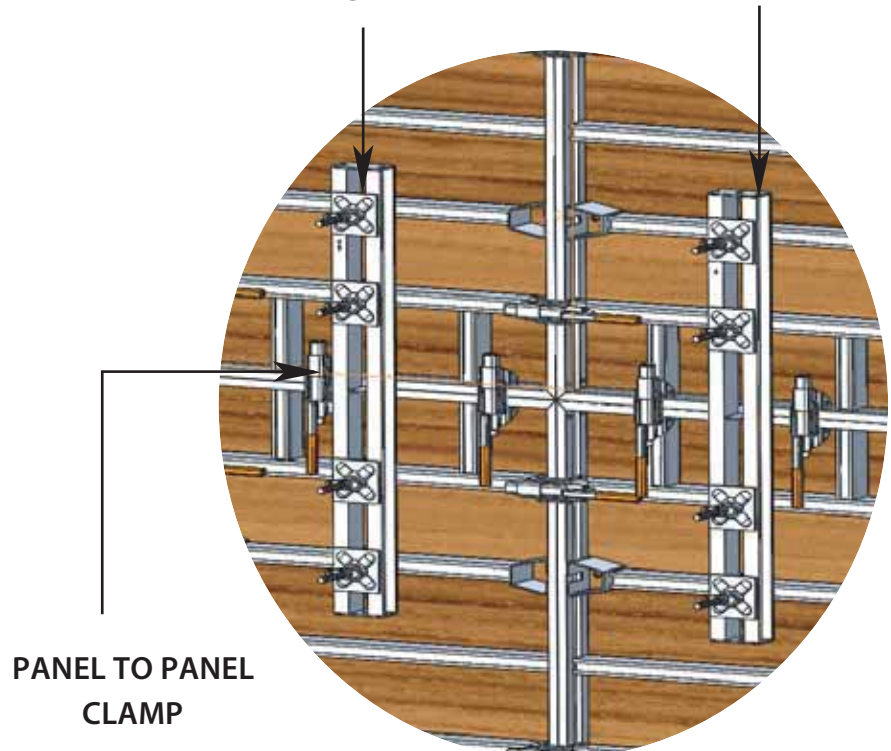

Use panel to panel clamp & universal waler for more than three meter high walls.

ADJUSTABLE COLUMNS SYSTEM

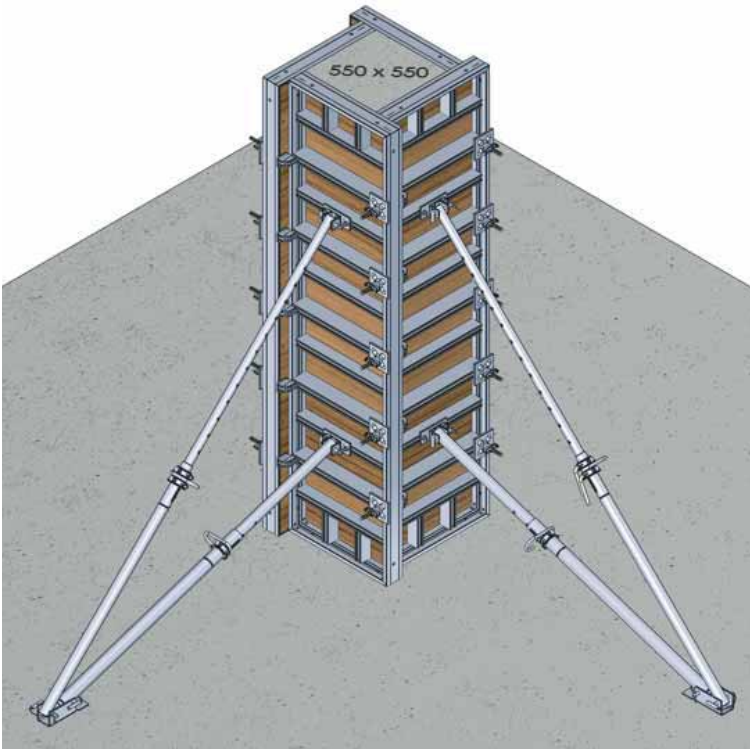

750mm WIDE MULTIPANEL

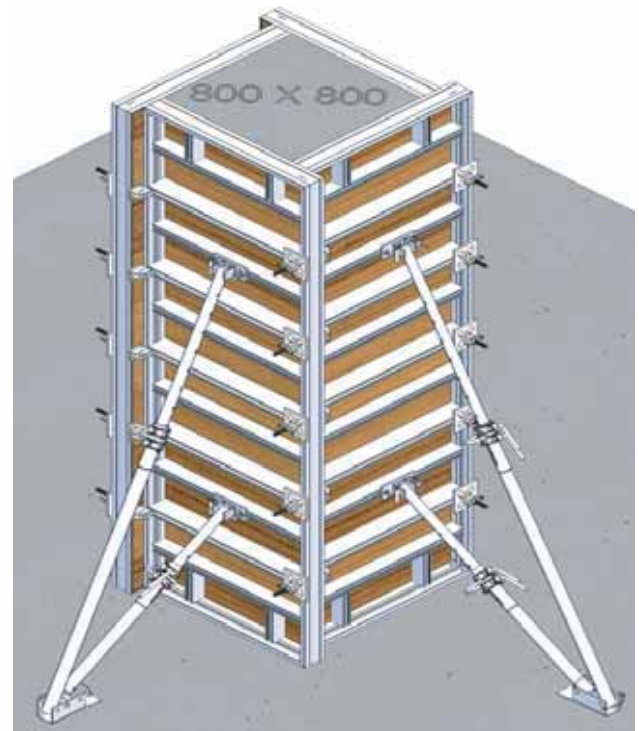

1000mm WIDE MULTIPANEL

Wall Formwork

COLUMN SYSTEM CHARACTERISTICS

Material	Aluminium Alloy 6061-T6
Sizes Range for 750 Panel	200x200 to 550x550
Sizes Range for 1000 Panel	200x200 to 800x800
Finish	Mill
Permissible Allowance Fresh	60kN/m ²

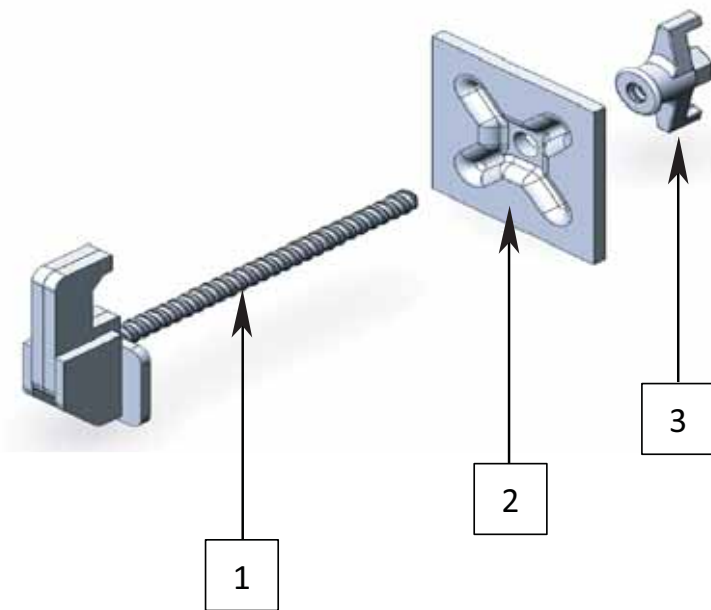
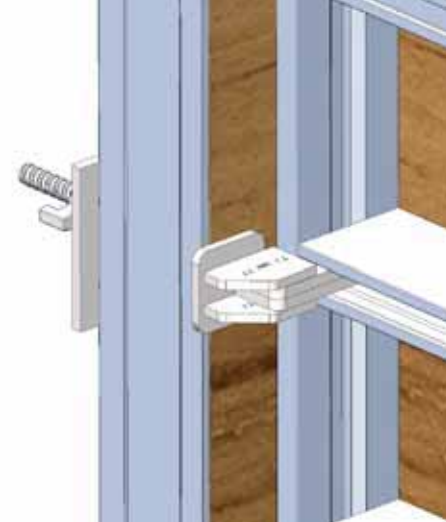
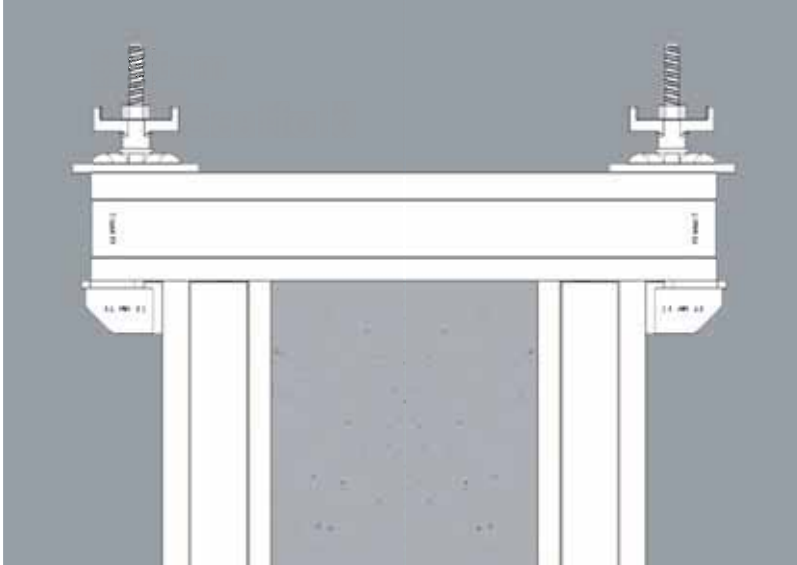

This clamp is used when connections hole doesn't match with each other or where panel to panel clamps cannot be used.

1 MULTI PANEL TIE ROD

2 SUPPORT PLATE

3 WING NUT

COLUMN WITH OUTER CORNER

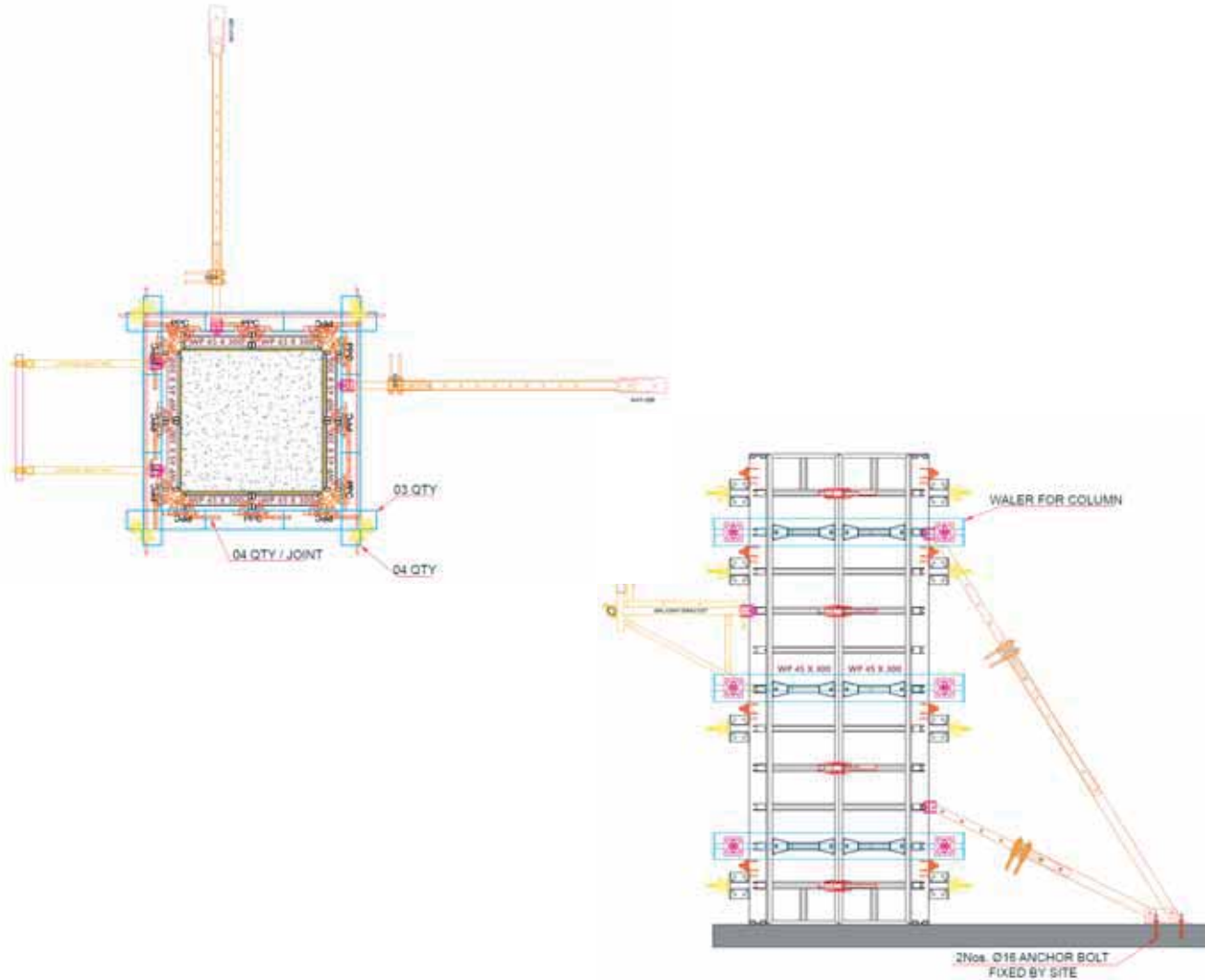

Wall Formwork

COLUMN WITH OUTER CORNER CHARACTERISTICS

Material	Aluminium Alloy 6061-T6	
Sizes for 1.5M Height	750x750mm	1000x1000mm
Sizes for 3.0M Height	750x750mm	1000x1000mm
Finish	Mill	
Permissible Fresh Concrete Pressure	60kN/m ²	

ADX AluPanel System Product Identification

COMPENSATION BETWEEN WALL PANELS

Compensation wood is kept between the two Multi panels to complete the formwork which is having small gaps. Two panels are then clamped between the compensation using adjustable panel clamp. Using Adjustable panel clamp sizes up to 300 mm of compensation timber can be used. Also use Universal Waler at tie rod hole position to avoid the panel deformation as shown in the below sketch.

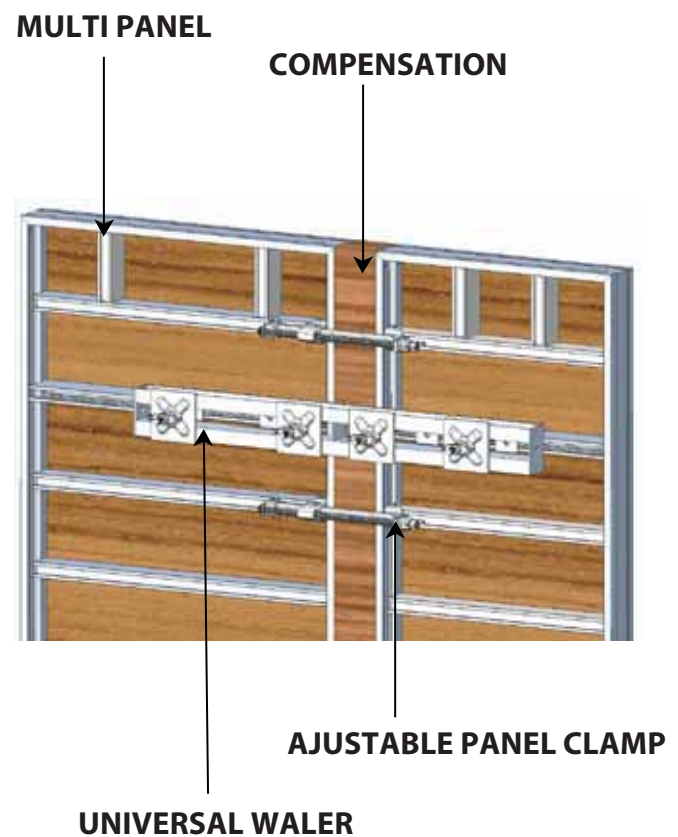
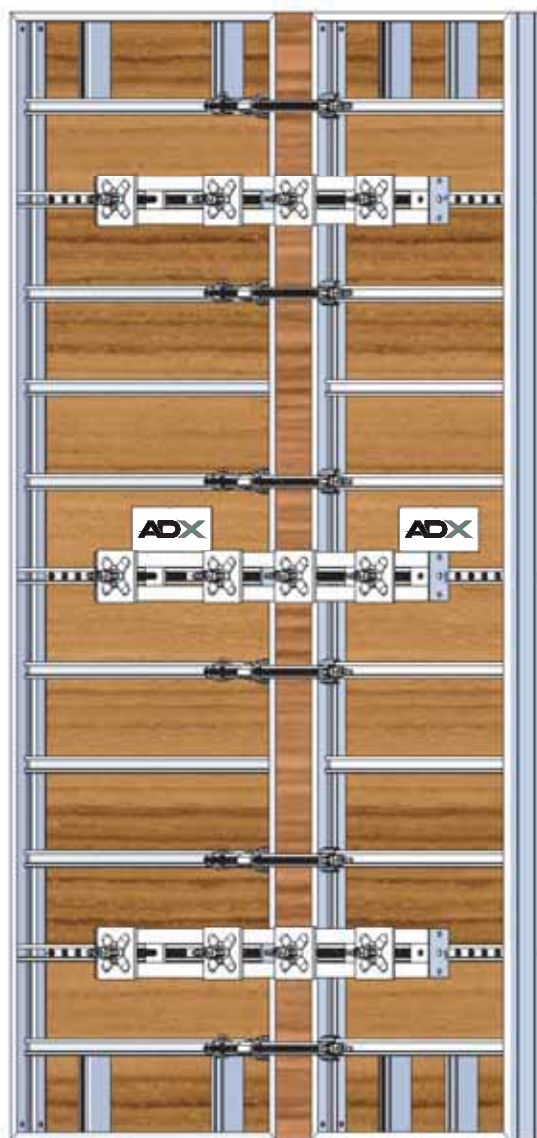

ADX AluPanel System Product Identification

WALL PANELS AT CORNERS

Using Multi-panels at the corners of the walls, there is no need of the compensation element (Timber) for wall width up to 500.0mm.

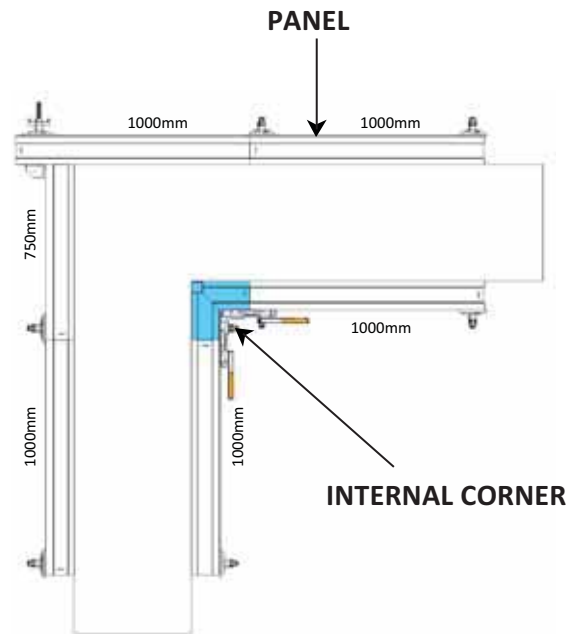
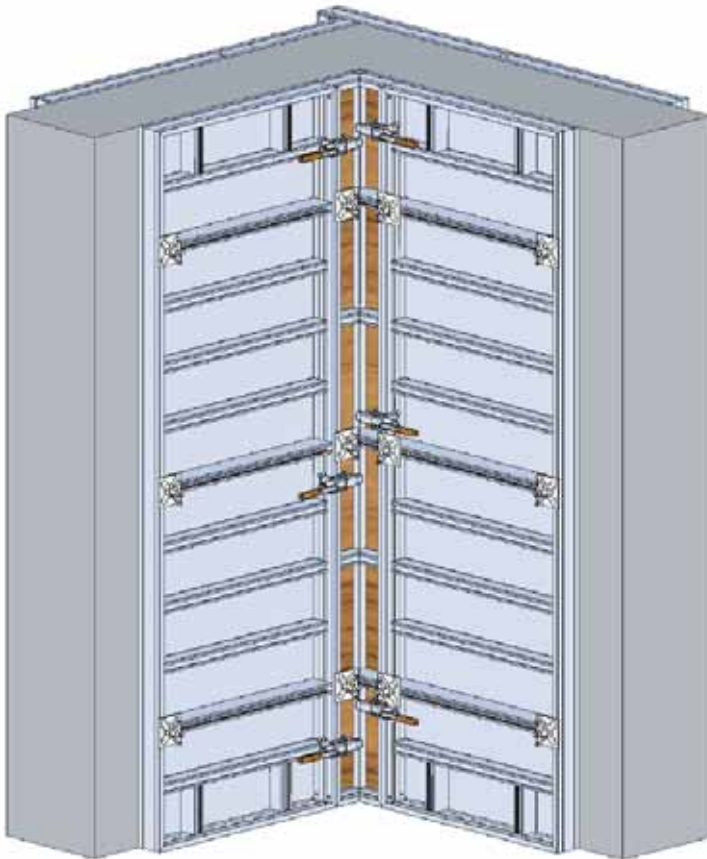

WALL PANELS AT T-CLOSURES

Wall panels at T-Closures can be easily assembled using multi-panels, this setup may or may not requires compensation element (Timber).

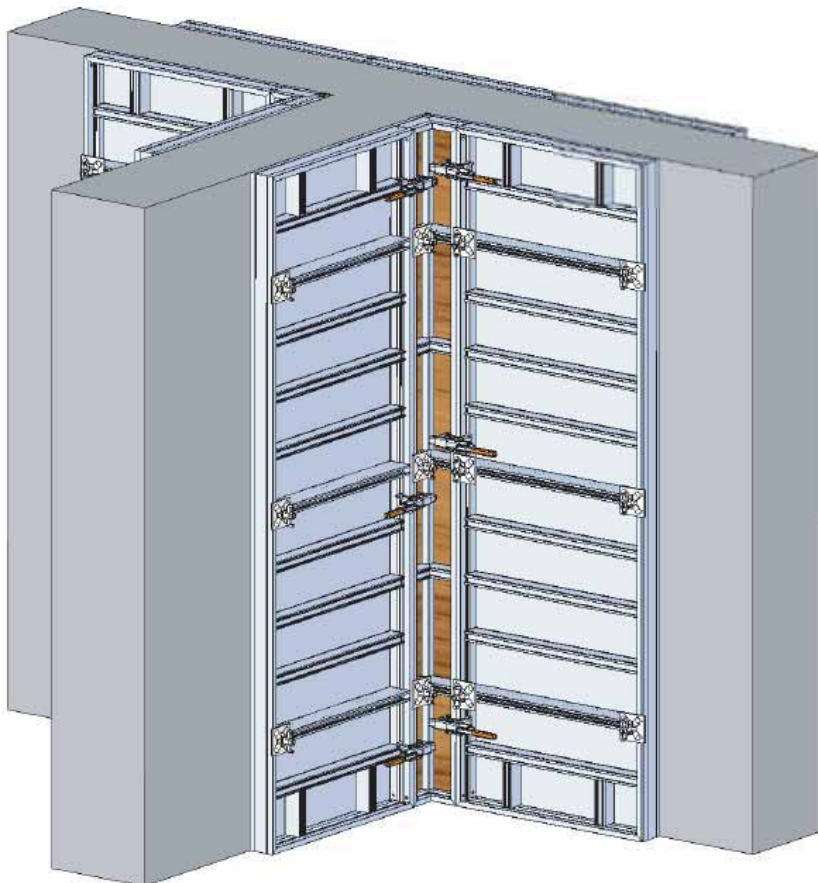
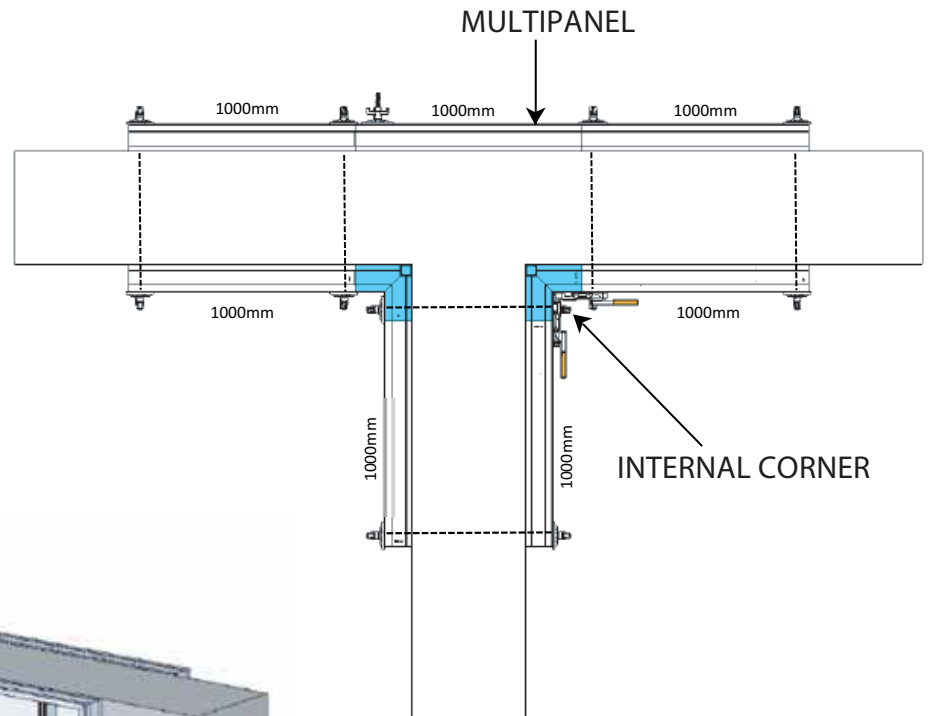

ADX AluPanel System Product Identification

WALL PANELS AT CONTINUING WALL

Existing walls can be continued using wall panels, the side off wall panels can directly touch to the face of the existing wall, as shown in image.

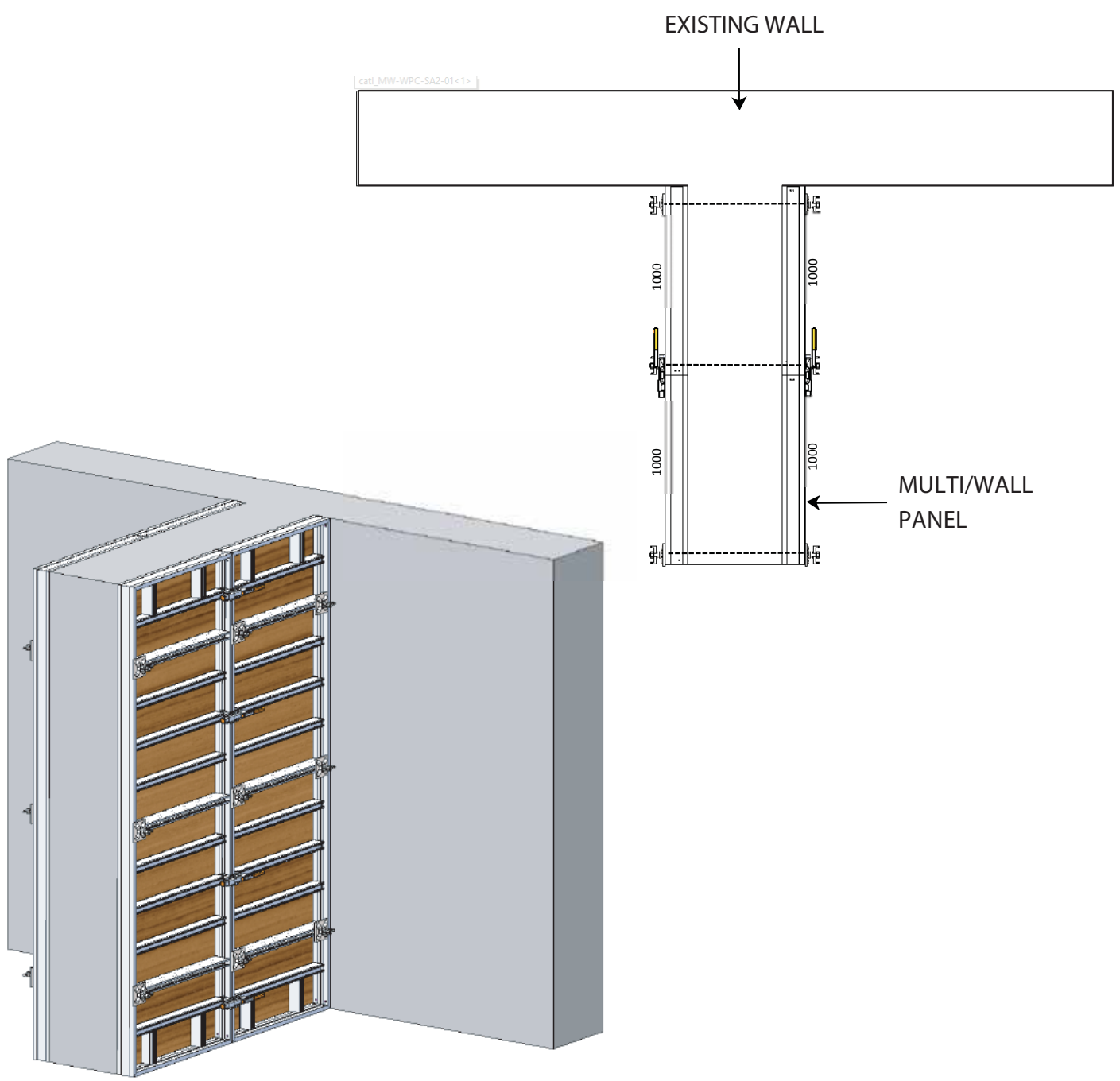

OUTSIDE CORNER 90°

Outside corner is a solution for the walls with sharp 90° turn, it is clamp to the wall panels or multipanel as per requirement of the site.

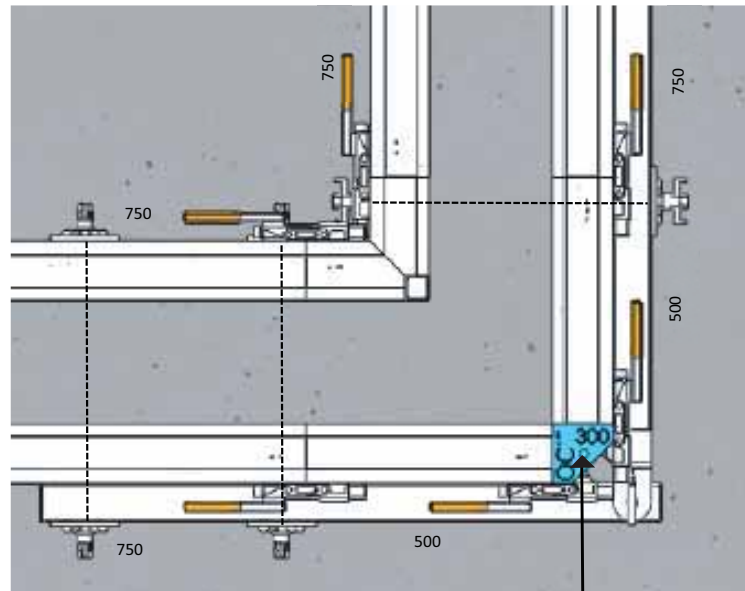
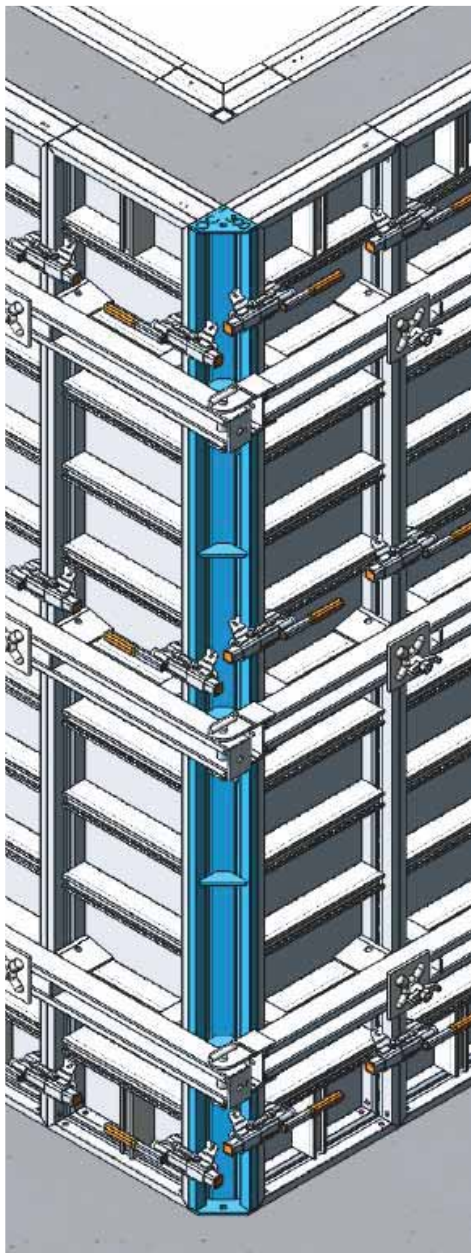

OUTSIDE CORNER

ADX AluPanel System Product Identification

SWING CORNER WITH HINGE WALER

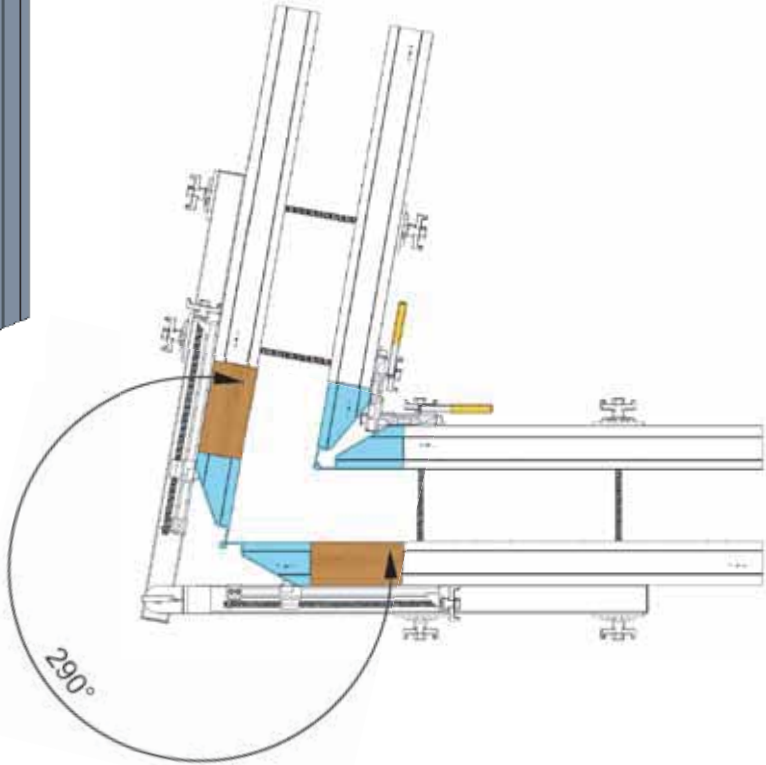
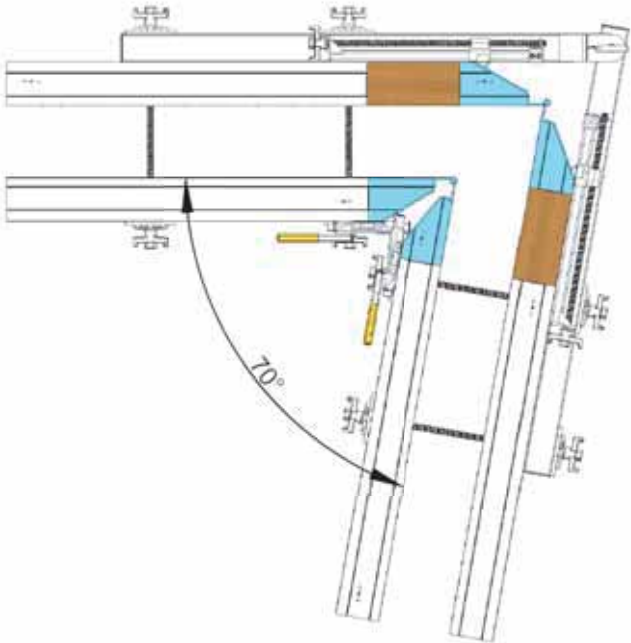
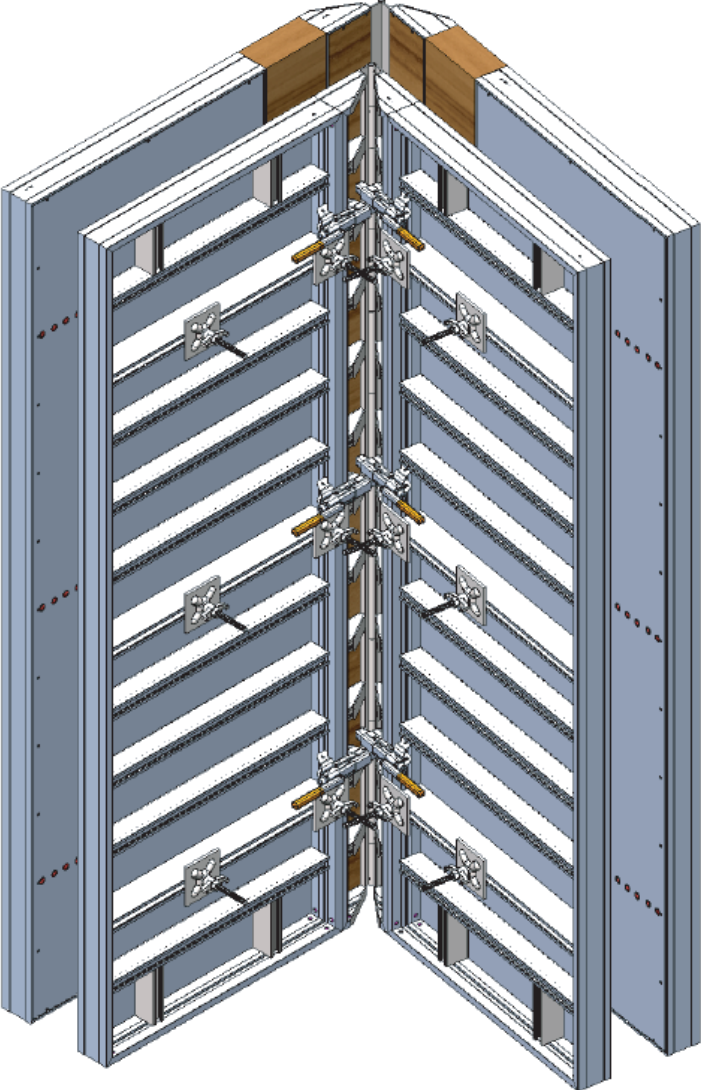

Wall Formwork

ADX AluPanel System Product Identification



ADX AluPanel System

Product Identification

SINGLE SIDED WALL SOLUTIONS

Single sided wall solutions are meant to be provided where the wall panels from both sides are not possible, single sided wall solutions is used for retaining walls. Structural members are arranged and fixed to panels to withstand the permissible loads acting on the panels.

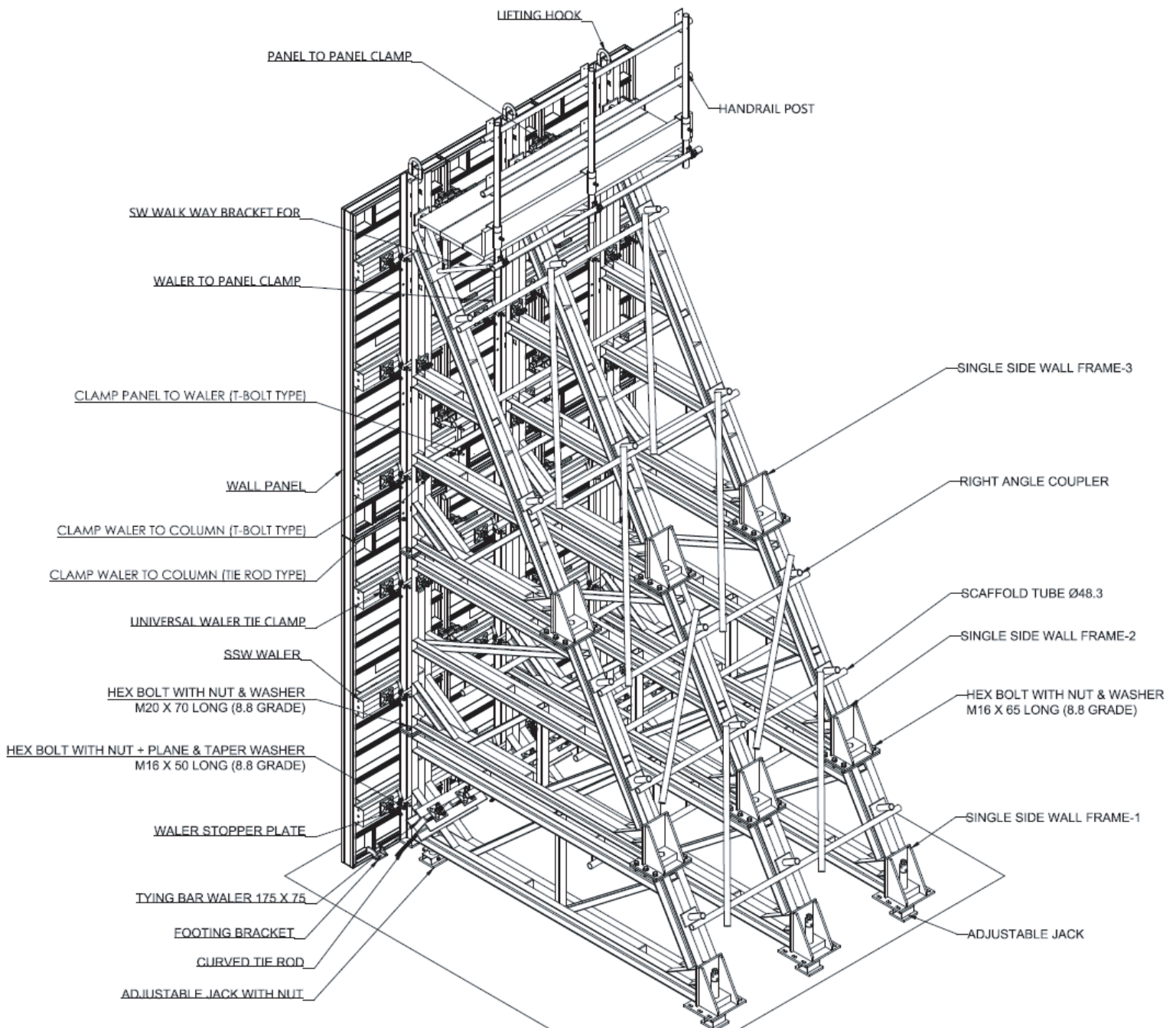

TYPICAL ARRANGEMENT OF SINGLE SIDED WALL

TABLA Modular Panel Wallform System (TB1) - Heavy Duty



TB1 - TABLA Modular Panel Wallform System

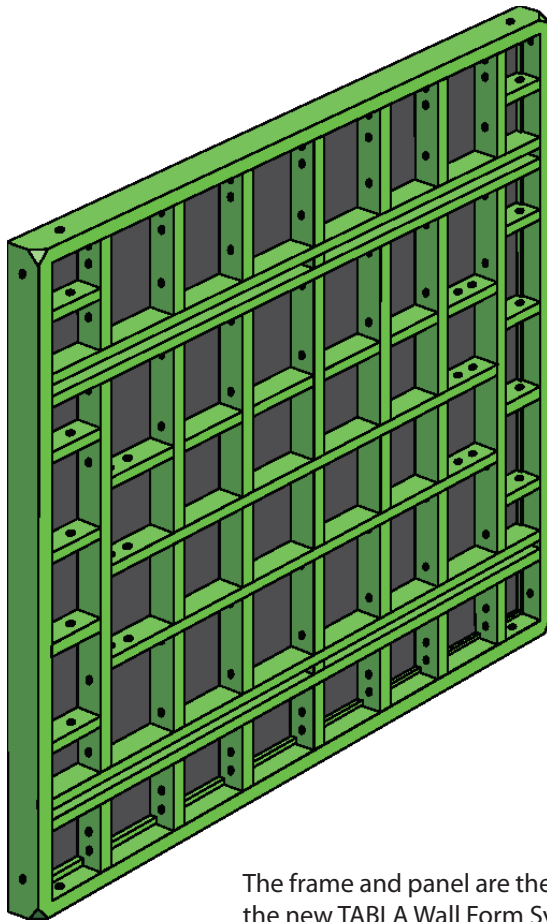

The frame and panel are the heart of the new TABLA Wall Form System.

The TABLA Wall Form System consists, mainly, of a modular steel frame with a plywood or plastic laminate panel facing, push-pull prop, scaffold bracket, alignment coupler, compensation waler, tie rod and lifting hook.

The heart of the System is the modular panel with a smooth-surfaced cladding attached to one side of a purpose-designed steel frame. Plywood panels could be used as cladding but Tabla recommends composite plastic panels to increase the ease of stripping and vastly extend the panel's cycling life span. Powder coated frames made of cold roll-forming steel supports the cladding.

Connection between the modular panels is accomplished through the use of the TABLA alignment coupler which greatly improves working efficiency when compared to time-consuming bolts or cumbersome U-clips. Additionally, compensation walers used at panel connection locations strengthen the integral rigidity of the wall forms.

Essential advantages of the TABLA Wall Form System are: high cycling turnover, easy operation, reasonable load, convenient storage and transportation, as well as low cumulative costs.

With TABLA's standardization of mechanized components, formwork erection has never been easier. A worker needs only a hammer to finish the job. Simple and efficient - that's the TABLA Wall Form System.

Wall Formwork

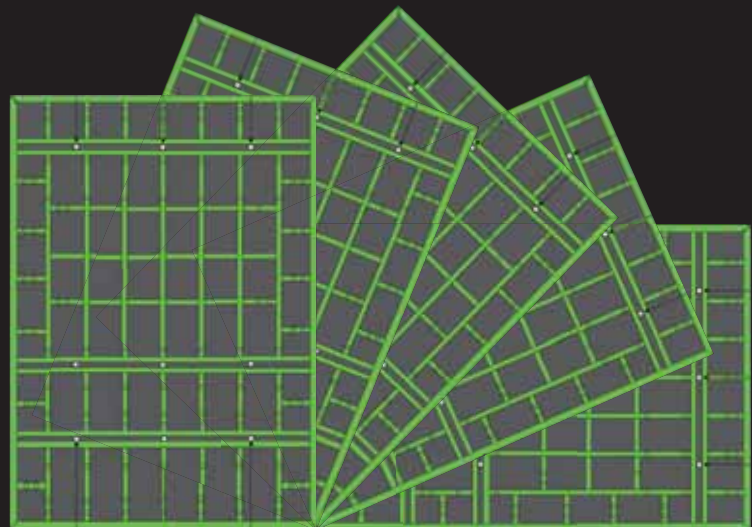

Flexibility in assembly is possible as necessitated by varied height requirements. The TABLA Wall Form Panels are designed to be used with equal ease both vertically and horizontally in any size. Their modular construction allows them to be aligned and secured in either configuration or with panels of different sizes.

Note: with the panel in the vertical position, the integral waler closest to the panel edge should always be at the bottom as illustrated in the diagram above.

Erection Components

Modular components

Modular components can be stacked together for convenient and safe lifts of multiple panels to the work deck. TABLA'S Wall Form panels are designed to nest for stacking and automatically align holes where the load can be secured with tie rods.

Holes located at each of the four corners are provided for securely attaching the lifting grommet. The TABLA Wall Form panels are designed to act as a base for the lift, negating the use of wood pallets.

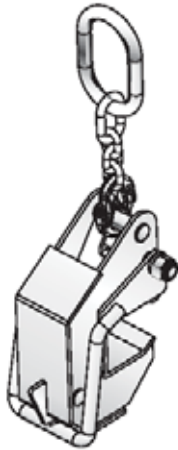

Single Panel Lifting Hook

For single panel lifts, the Lifting Hook is designed specifically to match the profile of the TABLA Wall Form framework. This design avoids stress to the panel and reduces any negative effect of force to the frame during lifting.

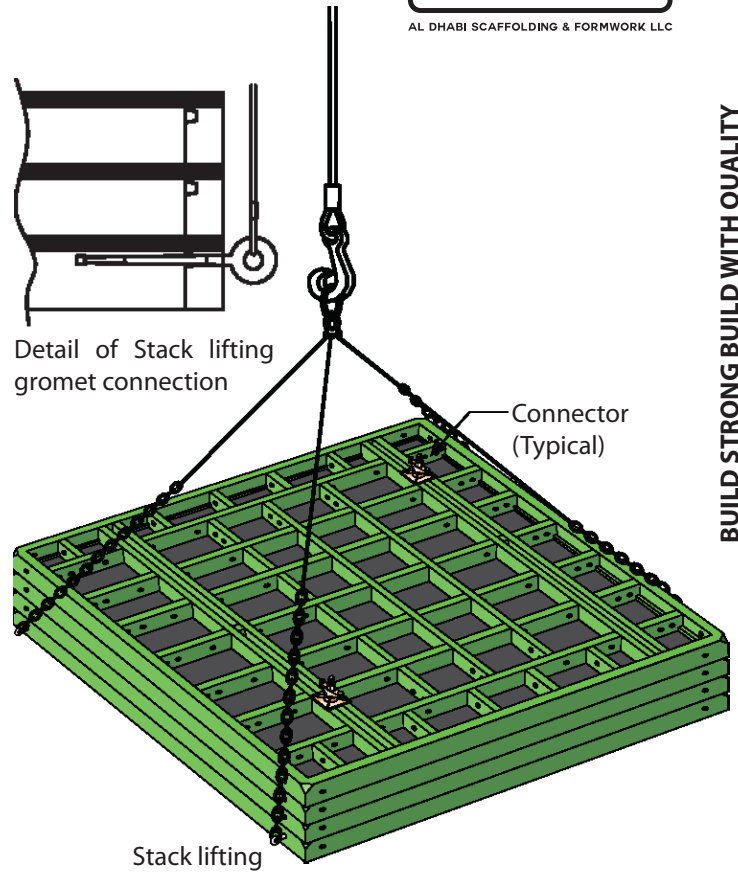

Stack lifting

BUILD STRONG BUILD WITH QUALITY

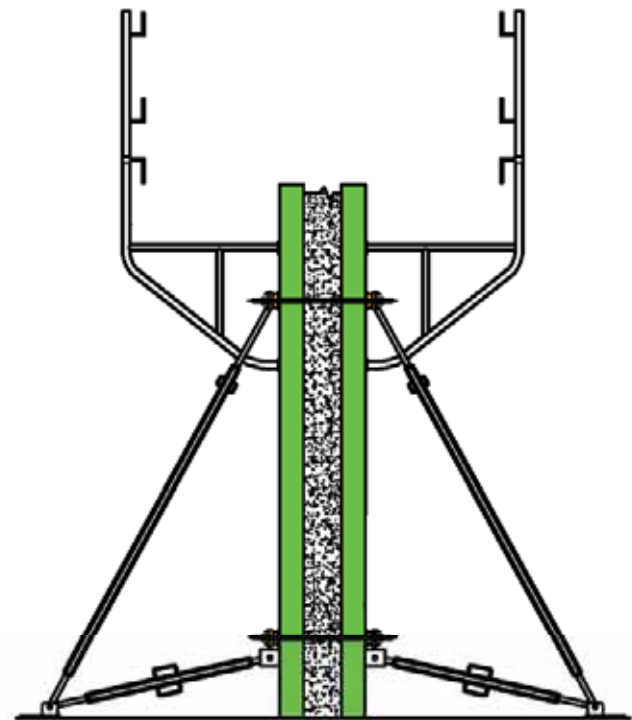
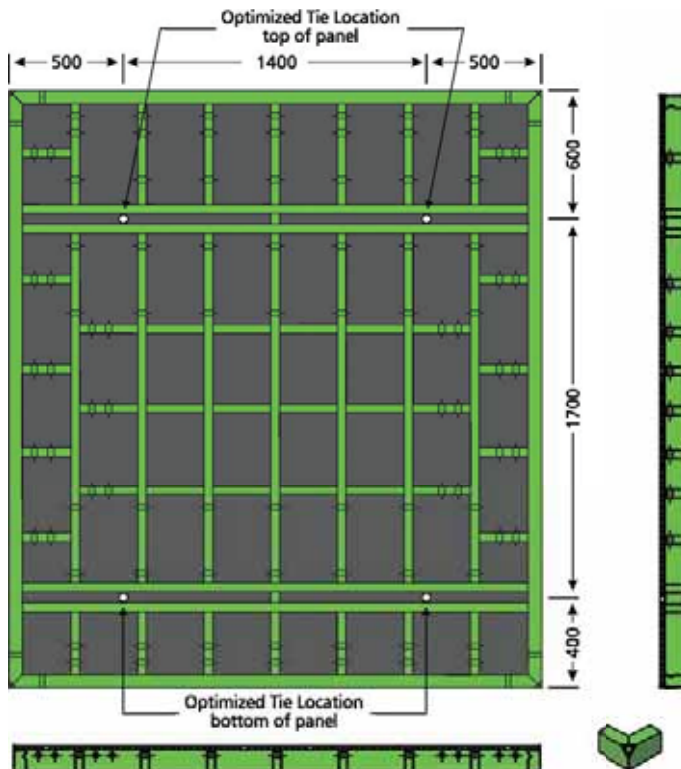

Cross section of the TABLA Wall Form System

Illustrated above are the four optimum tie locations. Ties can, however, be located in any position along the built-in horizontal waler as necessary to avoid rebar or any other obstruction within the form.

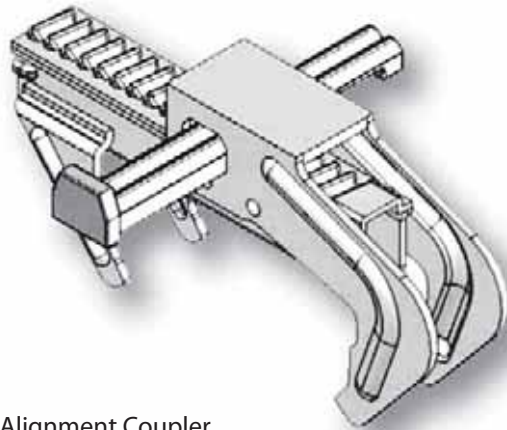

Alignment Coupler

Alignment Coupler

- Easy and simple connection between panels: fixing and loosening panels requires only a hammer.
- The unique design of the Alignment Coupler makes it possible to bear the 3D forces, ensuring the stable connection of panels, as well as preventing form displacement at panel joint.
- Its advantages are fast and easy operation, convenient dismantlement, less material waste. By ensuring the panel's strength, rigidity and flatness, it can also contribute to moulding a higher quality concrete face.
- The alignment coupler can be quickly and securely affixed to the framework in any orientation, i.e. vertically or horizontally, easily avoiding any requirement for complicated linkage or usage of bolts and U-clips.

Fixed Alignment Coupler

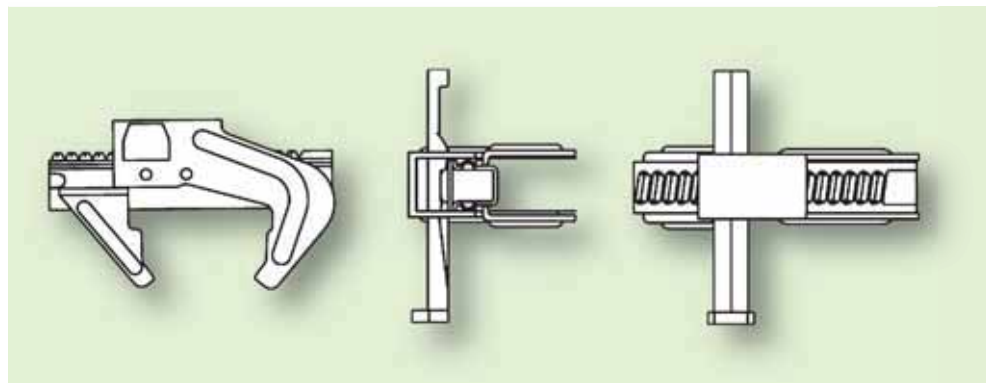

Alignment Coupler connections



Alignment coupler aligning and locking two panels together as rigidly as one unit

Using only a hammer, the Alignment Coupler can be quickly and securely affixed to the framework vertically, horizontally, at corners or joining offset panels. The connection created by the Alignment Coupler forces connected components to perform as a rigid single unit.

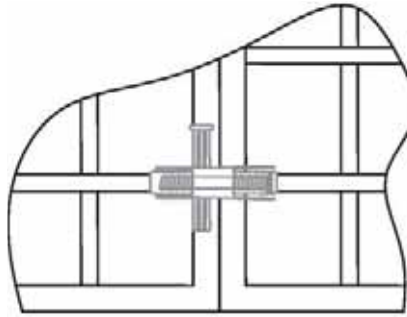

Standard panel connection. Typically only 2 to 3 couplers are required for 2.7m | 8' 10.75" height

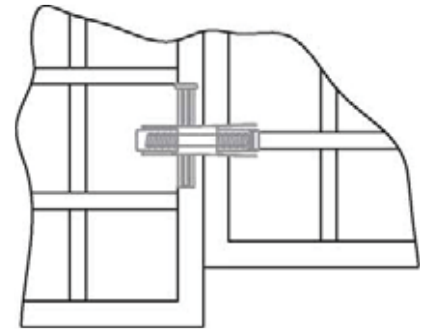

Connecting offset panels



A hammer is the only tool used to secure and uncouple the Alignment Coupler

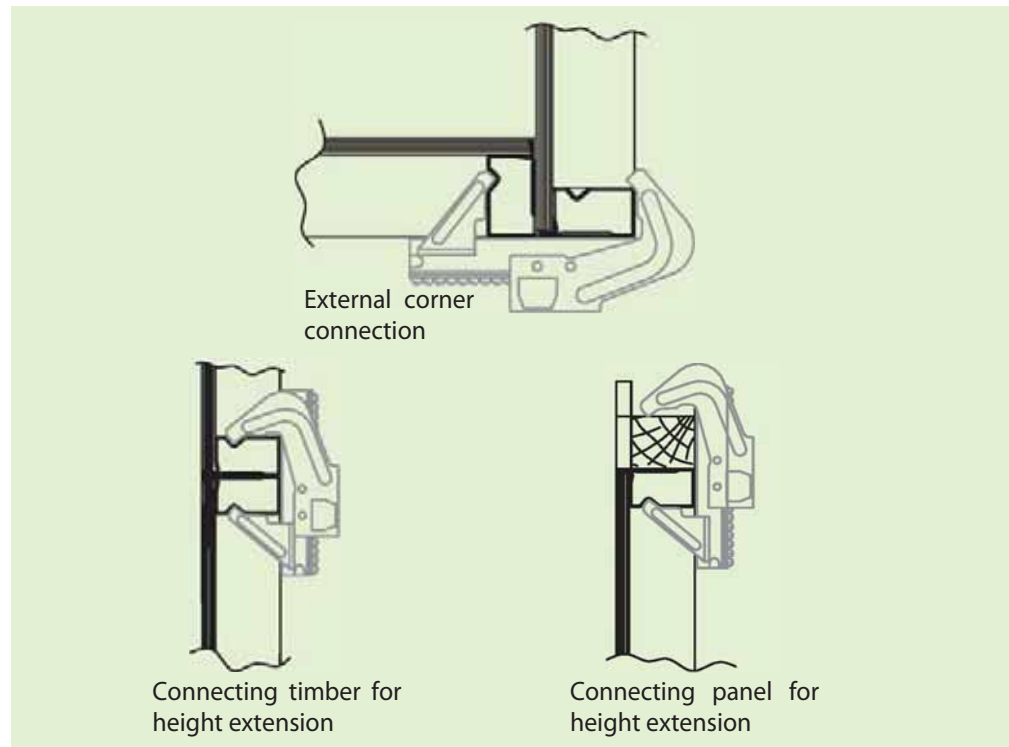

External corner connection

Connecting timber for height extension

Connecting panel for height extension

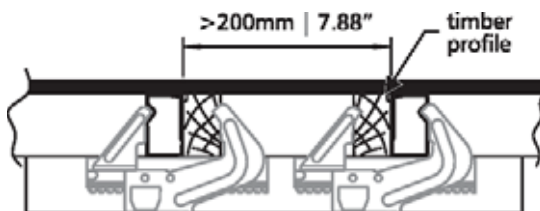

Infilling the filler between standard panels

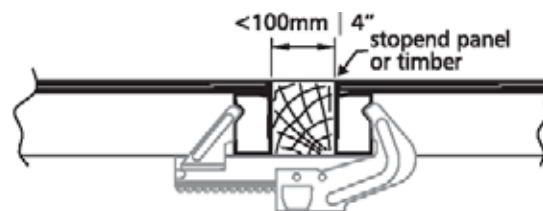

Connecting special-sized panels

Walers

Walers consist of dual profiled steel, special lifting hooks and wedge pins. They are easy to transport, operate and economical to maintain.

There are 4 types of Compensation Walers: projection waler, straight waler 850, straight waler 1300 and the adjustable waler which can accommodate any required angle.

Walers are used to strengthen the connection between components. They greatly improve the integral rigidity, flatness and stiffness of the formwork by spanning and locking to adjacent components.

They are used with panels, internal and external corners, bulkheads, infilling timber between panels and for height extensions.



Wall Formwork



The 90° Waler is designed to secure Wall Form internal corners

Walers, Coupler & Tie Rod Connections

BUILD STRONG BUILD WITH QUALITY

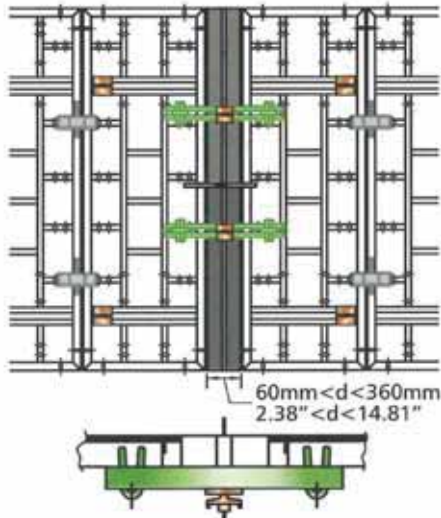

Connecting standard panels with filler

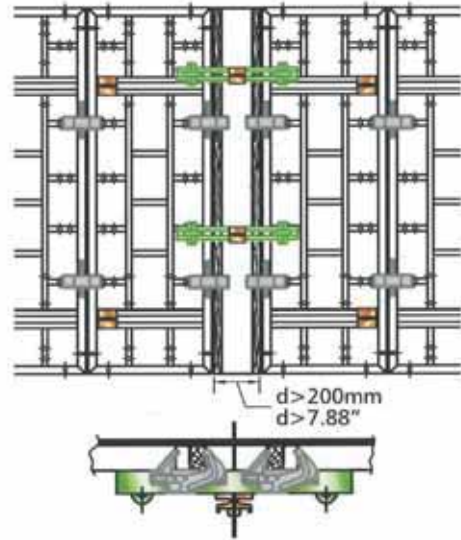

Connecting standard panels with frames

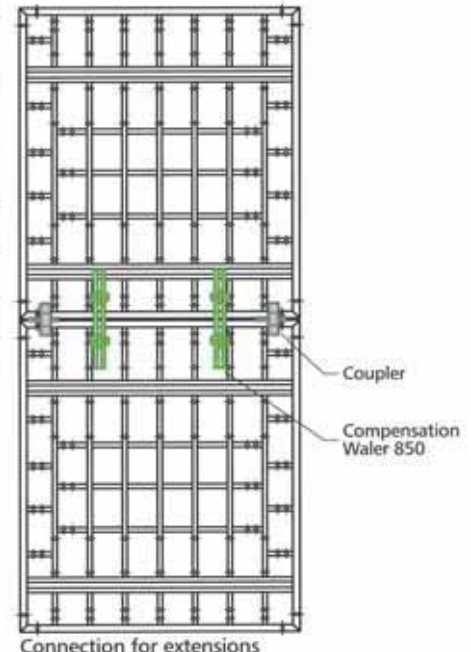

Connection for extensions

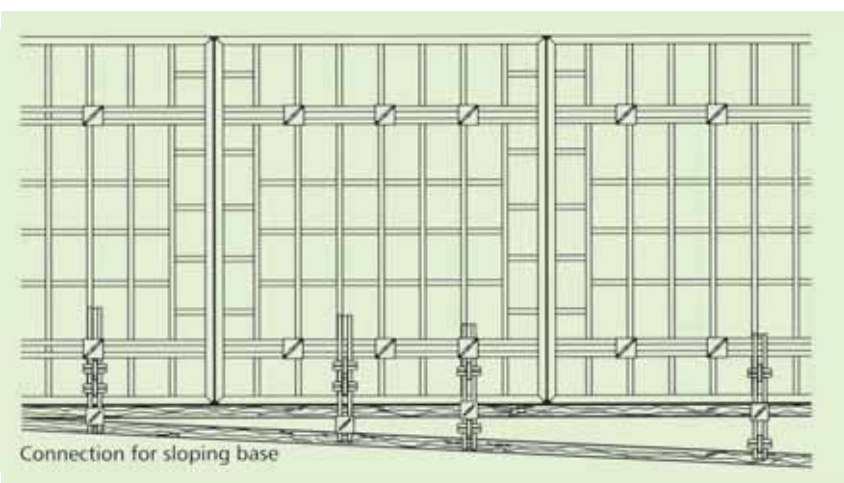

Connection for sloping base

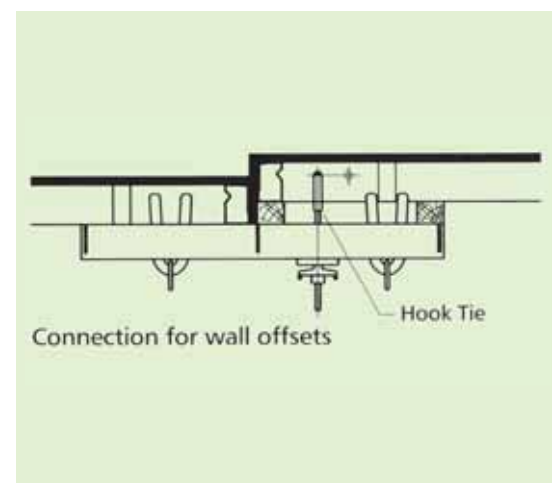

Connection for wall offsets

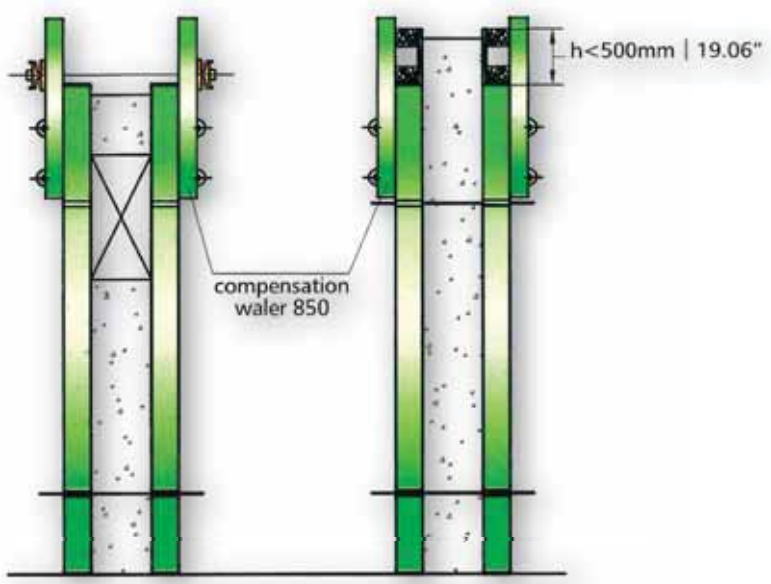

Tie rods can not be use where door or window openings are located. Instead, a straight waler is used to transfer the position of the tie rod to the top of the panel.

Walers can be used for timber height extension. Within a maximum height of 500mm | 19.0', there is no need to use additional tie rod.

Lifting Hook & Tie Rod

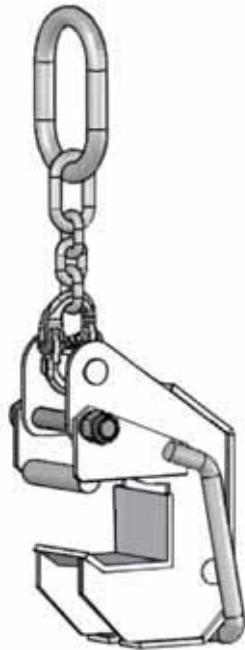

For single panel lifts, a lifting hook has been developed which is specifically designed to match the wall form frame profile. The matching fit avoids stress to the panel and reduces any negative effect of force to formwork during lifting.

The lifting hook's conformity to the panel profile allows it to be locked tightly onto the panel without compromising the panel's structural integrity, improving the safety of the lift.

A simple locking mechanism makes the lifting hook convenient and quick to lock onto a panel and easy to loosen for removal after use. This makes the ADSF lifting hook a very cost effective design.



Node Diagrams

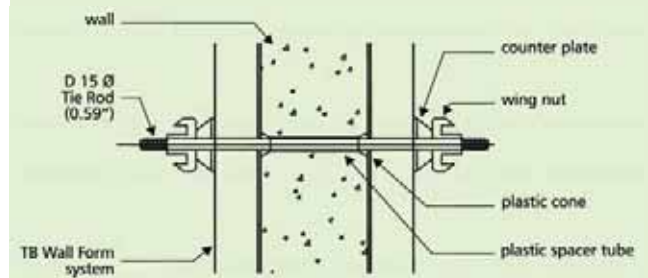

Cross section of thread-typed tie rod (typical simple tie)

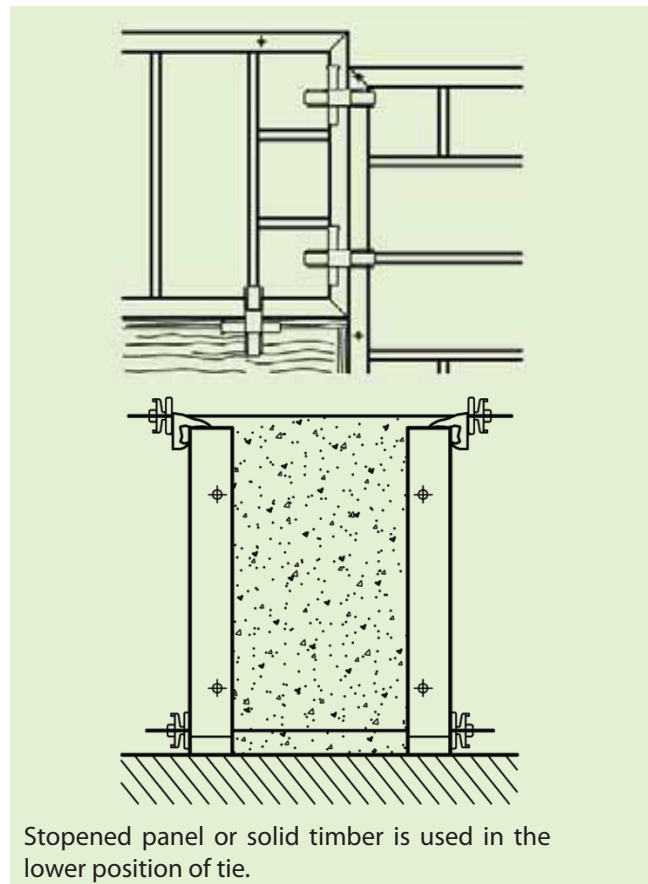

Push - Pull Props



Base plate connects the push-pull prop with the kicker brace and provides a stable base for orienting the wall.

Wall form system includes push-pull prop, kicker brace, scaffold bracket and crowbar.

- The push-pull prop and kicker brace are adjustable to meet different height and supporting angle.
- Scaffold bracket is a safe, light weight, platform support easy to install and dismantle.
- The crowbar, in conjunction with the levering corners, aids in formwork erection and dismantling.

The push-pull prop and panel are connected with the brace connector-2.

The horizontal kicker brace is connected to the panels with pins or bolts .



The push-pull prop assembled in the configuration ready to be connected to a wall form panel.



The push-pull prop's adjustable screw is used to adjust the verticality of a wall form panel.

BUILD STRONG BUILD WITH QUALITY

Scaffold Brackets & Connectors



Scaffold brackets connected to wall form panel



Bolts or pins are also connect the upper and lower pivot with the panel

Engineering Details Core Tube & T-Junction Walls

T-Junction Walls

Wall thickness is easily varied with the use of Stopend Panels or precisely sized timber in place of the Stopend Panels.

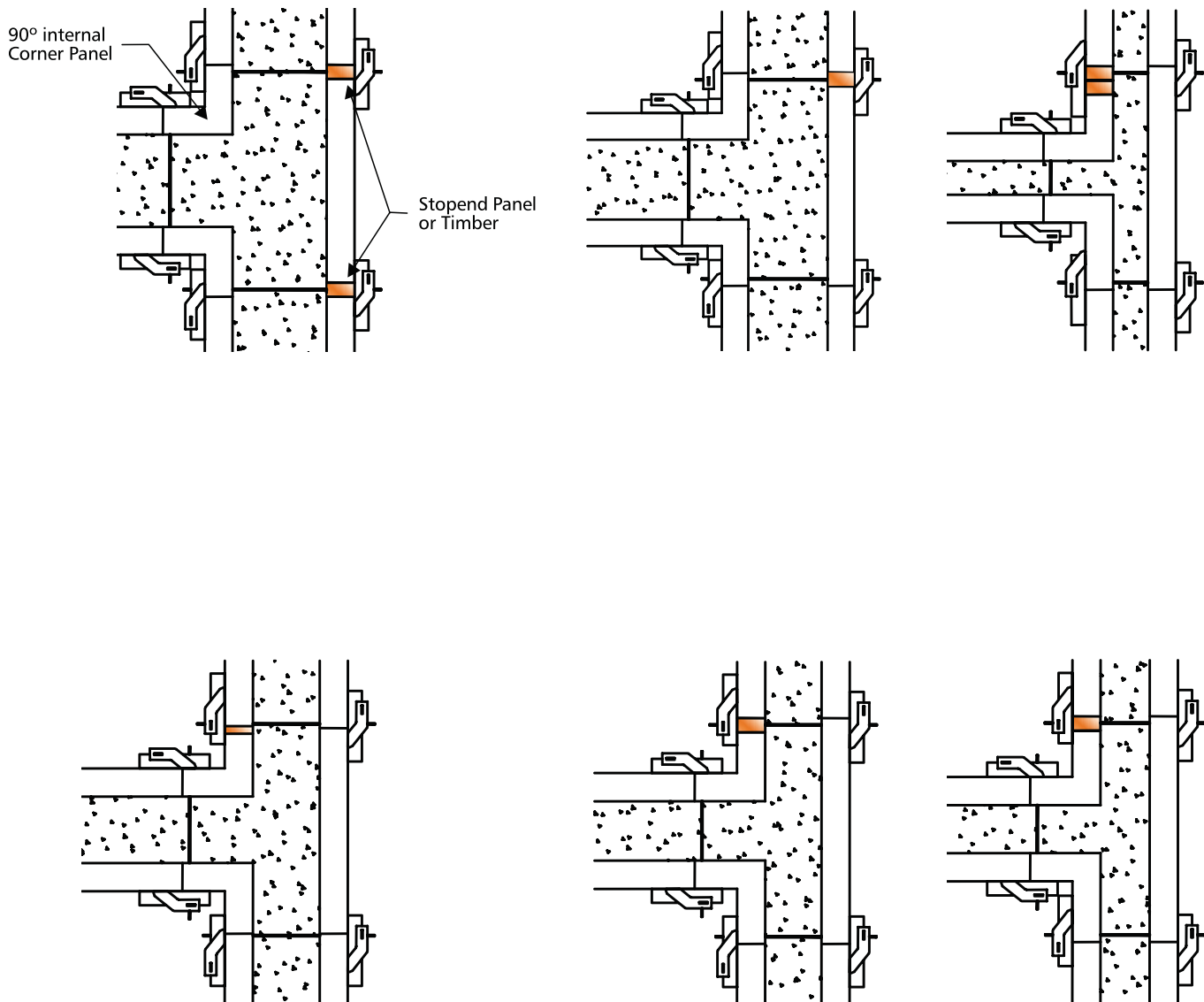

BUILD STRONG BUILD WITH QUALITY

90° Waler & Stopend

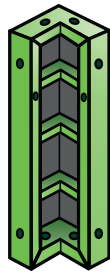
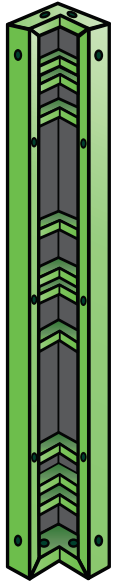

90° Corner

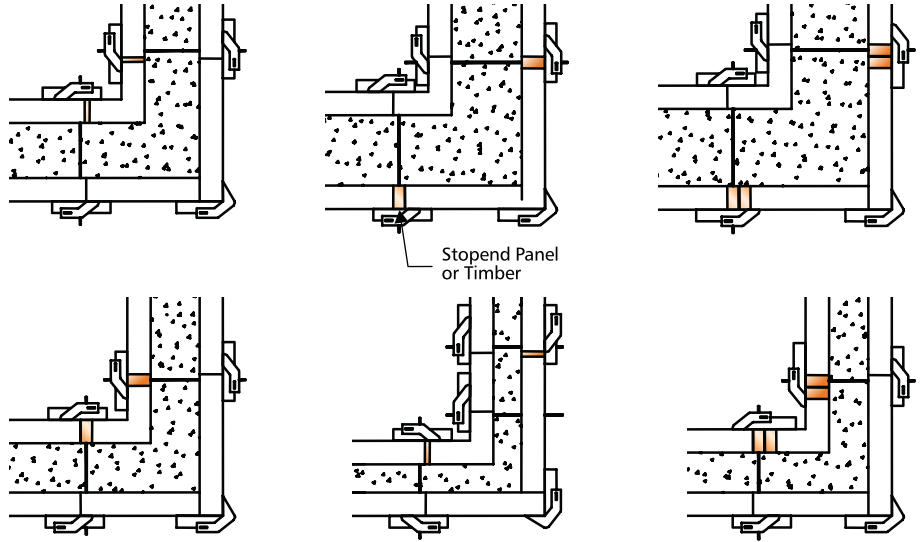

90° Waler

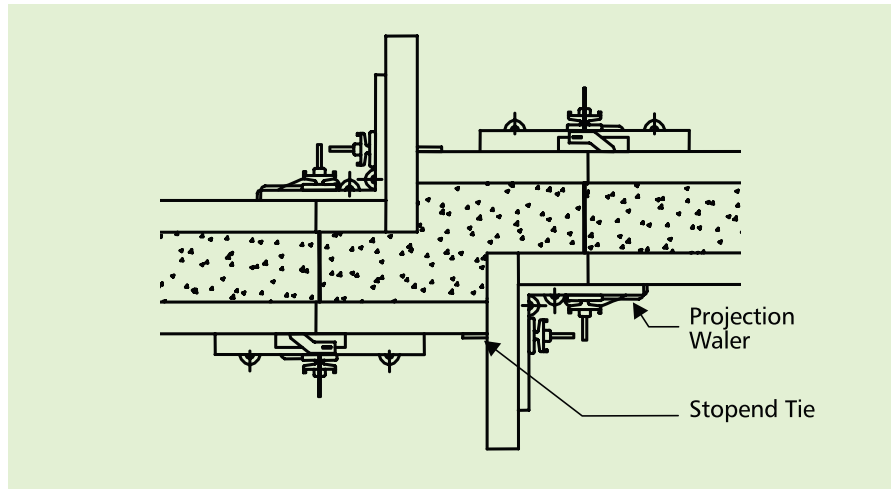

Stopend

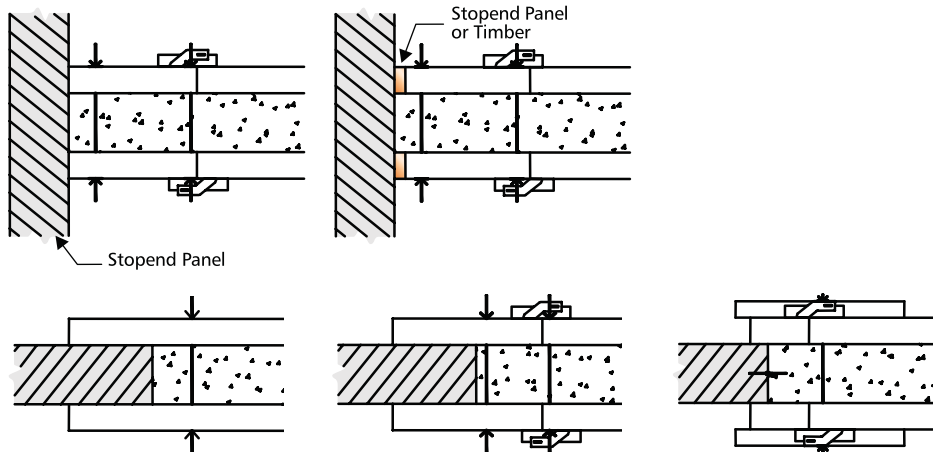

Core System

The Tabla TB-1 Form System can also be used in conjunction with our crane independent Tabla Self Climbing Form System.

SELF LIFTING INTEGRATING CORE (SLIC) FORM SYSTEM

- Capacity: 1.42 kN (320,000Lbs).
Speed: 0.03 m/s (6FPM).
Self climbing, care free operation.
- 4 hydraulic jacks for typical core form.
- Central operating station. self diagnostics.
- Hydraulic operated telescopic root beams.
- Inner and outercore forms rollback for cleaning.
- Solid platform upper deck to allow the rebar to be installed safely as the lifter rises.
- Laser Measurement System to allow pouring of the core wall to any height up to 4.25 meters. This can be programmed on the main control panel.
- The Hydraulic System will be a self leveling within (12mm) system so that all components remain level during the raising stage.
- The "Root Beams", are also hydraulic to allow adjustment for alignment purposes. The feet will incorporate self forming pockets that will retract with the Root Beams.
- There will be a lower Root Beam with hydraulic jacks for stabilizing.
- The Control Box will be touch screen and will have step by step pictorial procedures and fault screen. programmable distance, onboard diagnostics that can be communicated remotely via modem.



Self Lifting

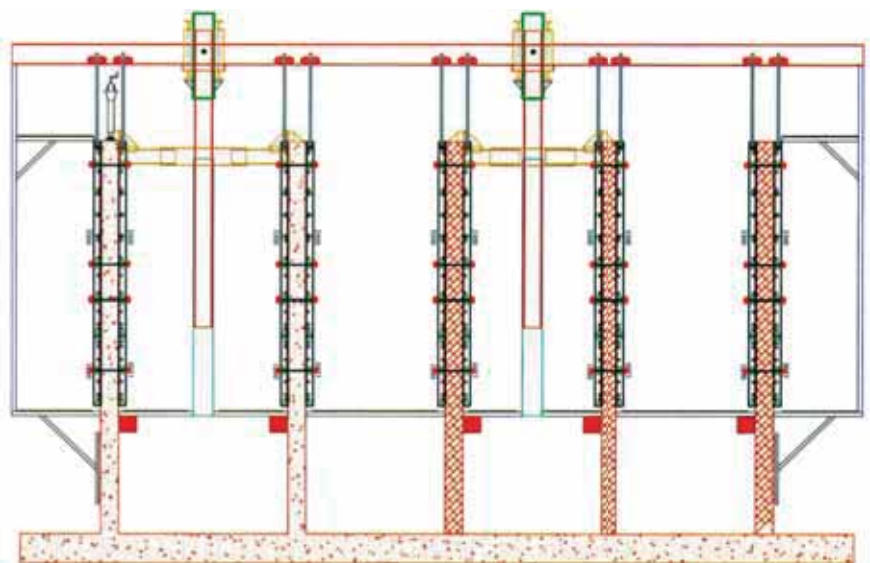

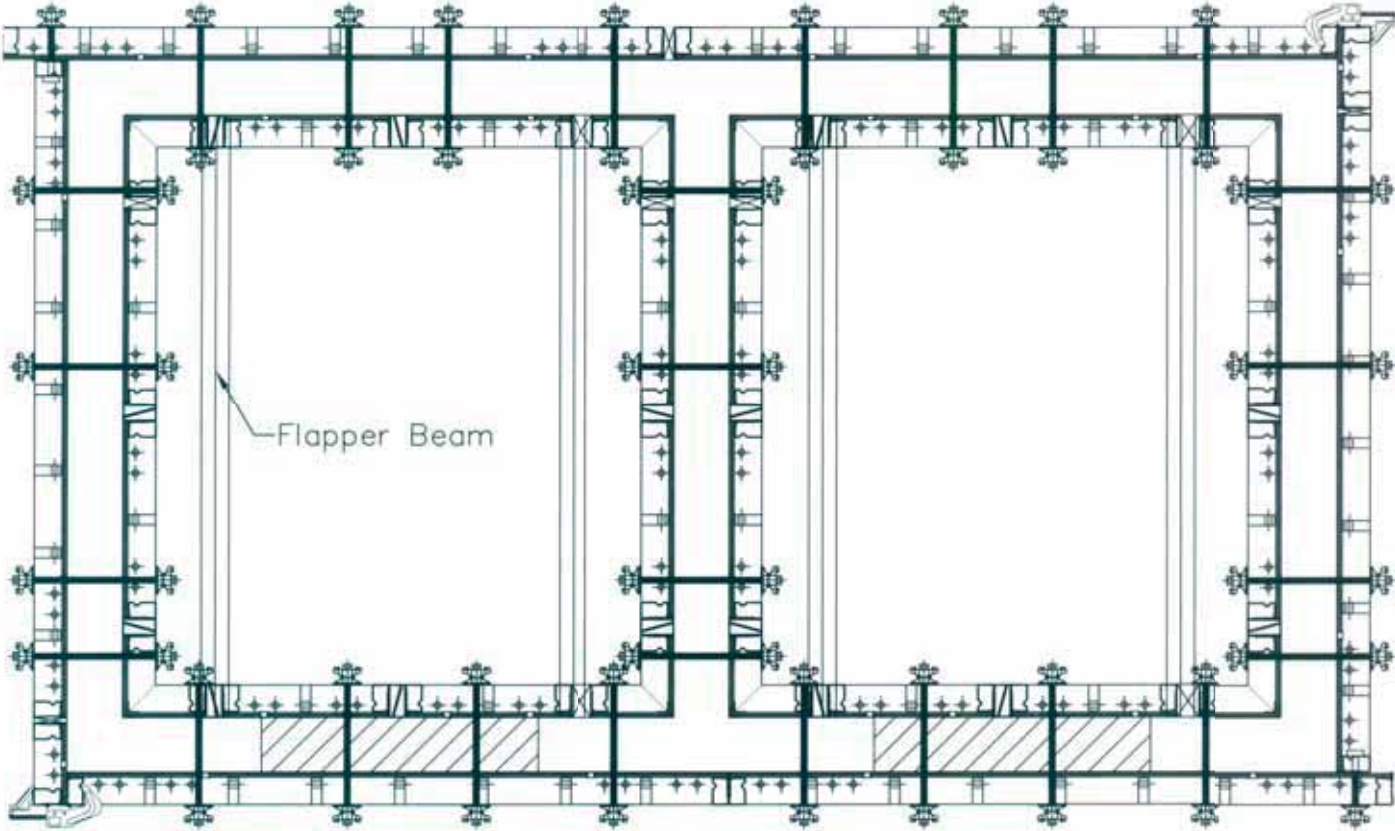

CRANE LIFTED OPERATION

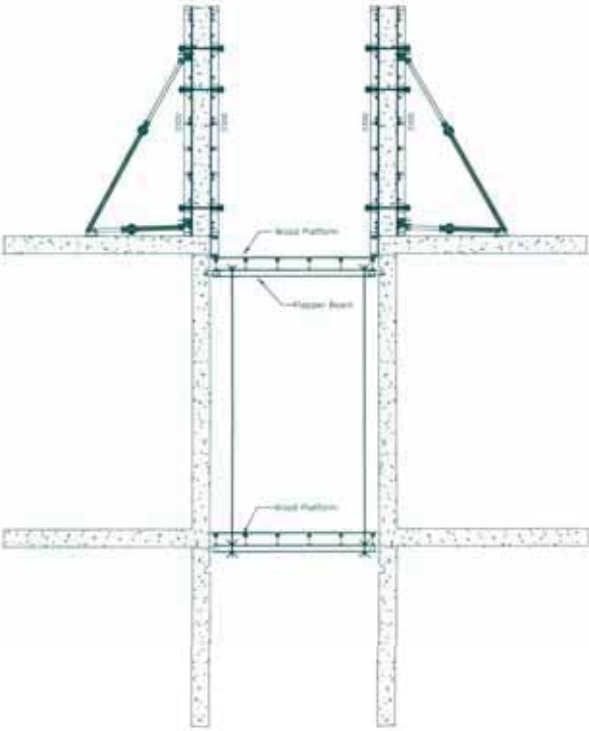

Build Landing Bracket

TABLA TB1 Landing Bracket

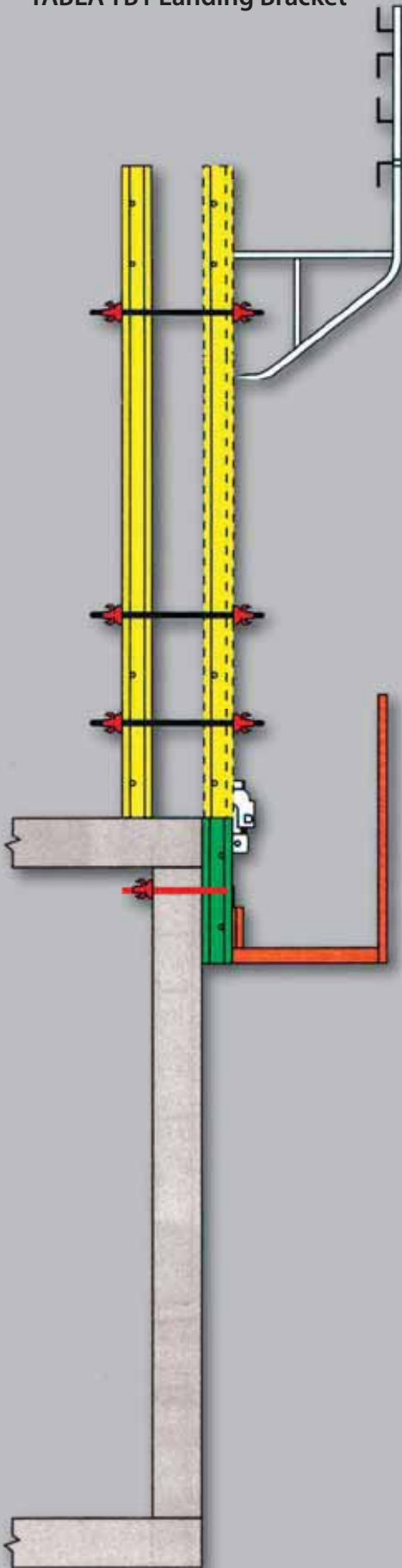

A self-aligning and winning combination

The Landing Bracket is the latest Wall Form component that demonstrates Tabla's continuing commitment to innovative and reliable products.

The Landing Bracket is a combination of a rigid walkway plus a uniquely designed climbing bracket. The two vertical funnels in the bracket are designed to fit snugly over the two special ties from the previously poured concrete wall. When attached to a Wall Form panel with Alignment Couplers the unit is lowered over the tie rods from the previous pour and the new form is placed in perfect alignment. Workers can now be at a safe distance from the form when it is being lowered. The Landing Bracket is safe and easily connected to the previous pour.

Safe, fast, efficient.

Another innovative product from the people that brought you the fastest shoring system in the world.

BUILD STRONG BUILD WITH QUALITY



Tabla Tb1 Climbing Platform



[Vertical walers may be applied for extra stiffness]

Two Sided Walls and columns

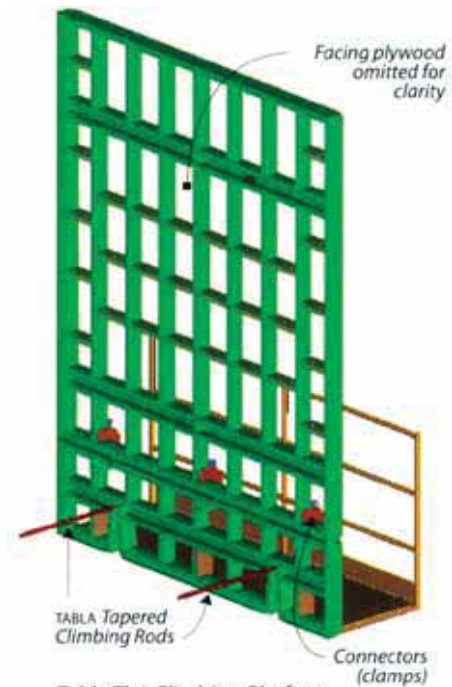
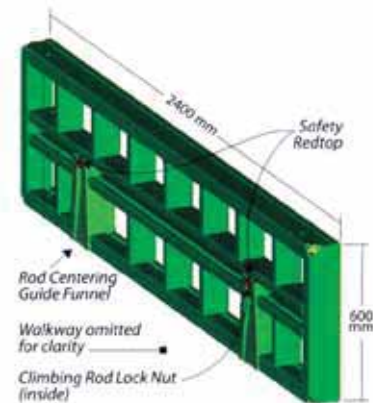
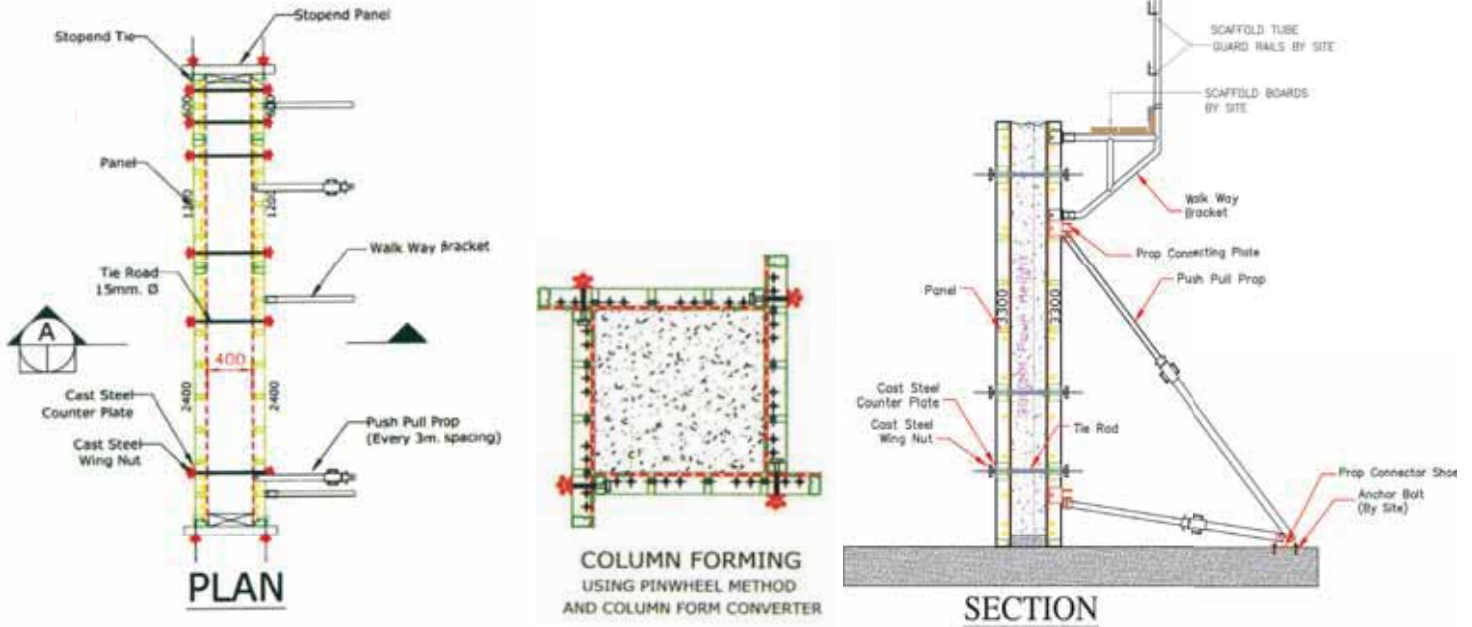

One Sided Walls

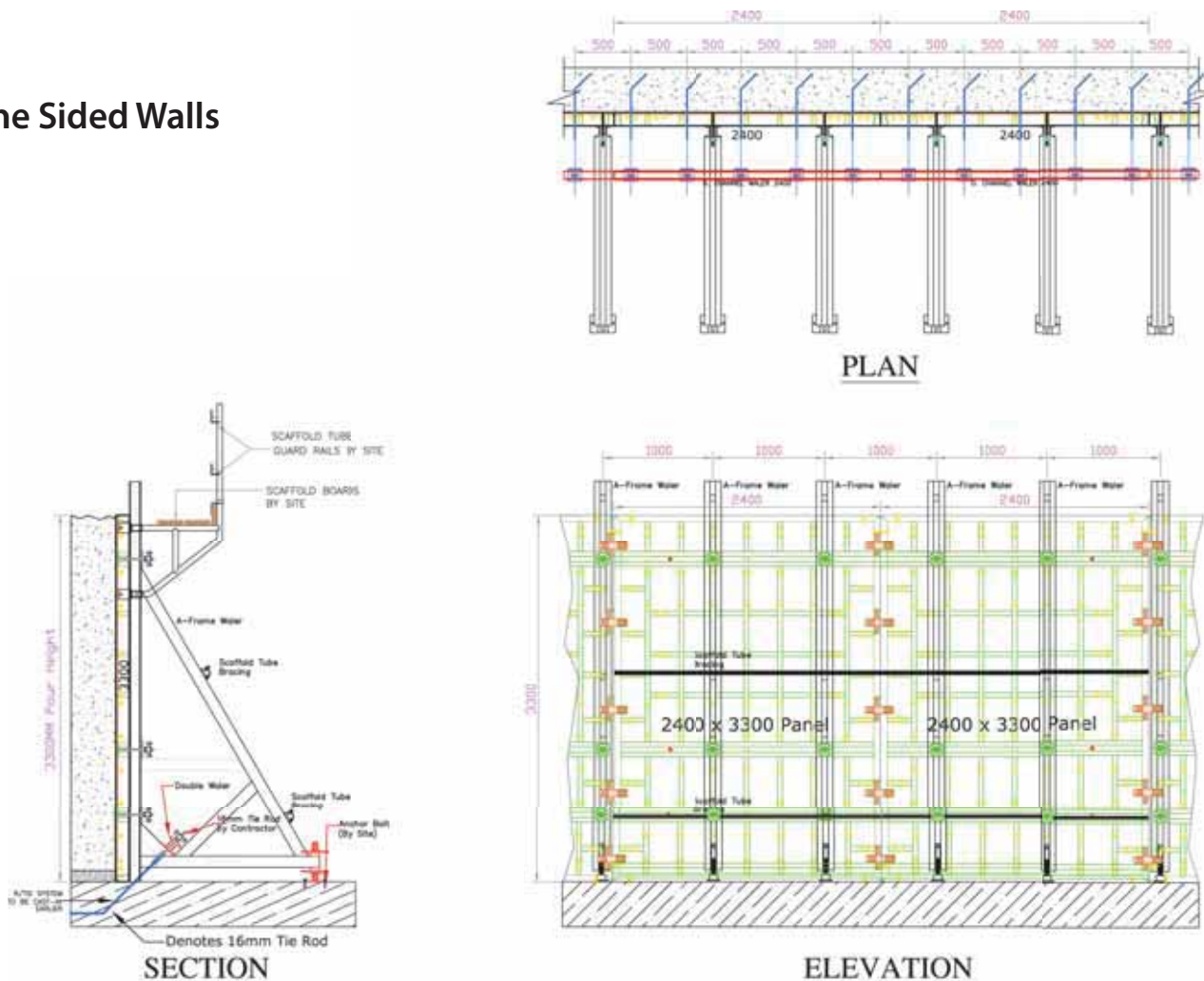

Components Wall Panels

2700 Series Wall Panels						
Item Code	mm	ft	m ²	ft ²	kg	lbs
W240270	2400x2700	7'10.5"x8'10.25"	6.48	69.8	395.82	872.6
W120270	1200x2700	3'11.25"x8'10.25"	3.24	34.9	214.84	473.6
W90270	900x2700	2'11.44"x8'10.25"	2.43	26.2	169.21	373.0
W72270	720x2700	2'4.31"x8'10.25"	1.94	20.9	138.49	305.3
W60270	600x2700	1'11.63"x8'10.25"	1.62	17.4	123.26	271.7
W30270	300x2700	11.81"x8'10.25"	0.81	8.7	74.11	163.4

■ **2700 series wall panels**
Wall Panels are fitted with 18mm plywood



W240270



W120270



W90270

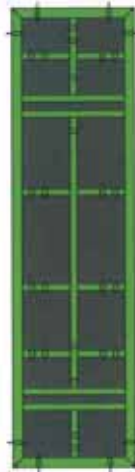

W72270



W60270



W30270

■ **3300 series wall panels**
Wall Panels are fitted with 18mm plywood

3300 Series Wall Panels						
Item Code	mm	ft	m ²	ft ²	kg	lbs
W240330	2400x3300	7'10.5"x10'9.88"	7.92	85.3	457.61	1008.9
W120330	1200x3300	3'11.25"x10'9.88"	3.96	42.6	207.25	456.9
W90330	900x3300	2'11.44"x10'9.88"	2.97	32.0	201.31	443.8
W72330	720x3300	2'4.31"x10'9.88"	2.38	25.6	165.93	365.8
W60330	600x3300	1'11.63"x10'9.88"	1.98	21.3	147.51	325.2
W30330	300x3300	1'81"x10'9.88"	0.99	10.7	87.79	193.5

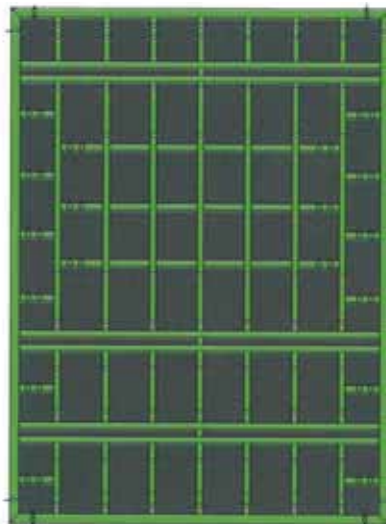

W240330

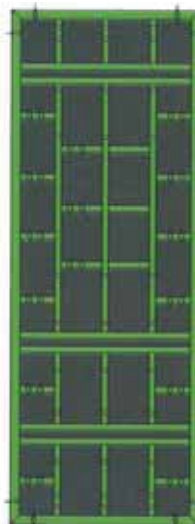

W120330

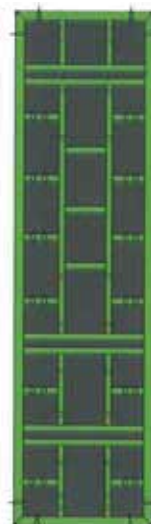

W90330



W72330



W60330



W30330

Wall Panel & 90° Corner Panels



1200 series wall panels

Wall Panels are fitted with 18mm plywood

1200 Series Wall Panels						
Item Code	mm	ft	m ²	ft ²	kg	lbs
W120120	1200x1200	3'11.25"x3'11.25"	1.44	15.5	99.94	220.3
W90120	900x1200	2'11.44"x3'11.25"	1.08	11.6	79.82	176.0
W72120	720x1200	2'4.31"x3'11.25"	0.86	9.3	68.74	151.5
W60120	600x1200	1'11.63"x3'11.25"	0.72	7.8	59.53	131.2
W30120	300x1200	11.81"x3'11.25"	0.36	3.9	35.97	79.3

Wall Formwork

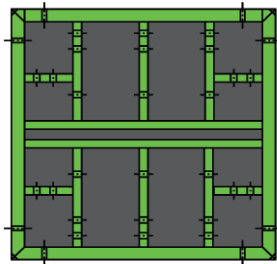

W120120

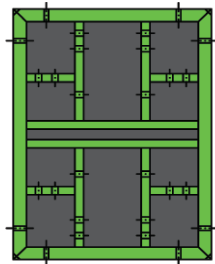

W90120

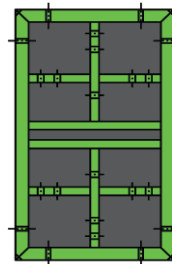

W72120

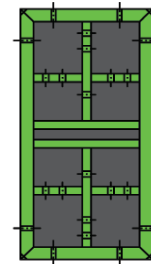

W60120



W30120

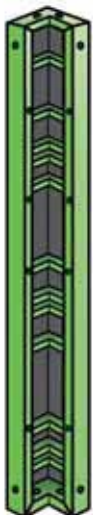

C3030330



C3030270



C3030120

Corner Panels

Corner Panels are fitted with 18mm plywood

Corner Panels						
Item Code	mm	ft	m ²	ft ²	kg	lbs
CI3303030	(300+300)x3300	(11.81"+11.81") x 10'9.88"	1.98	21.3	128.71	283.8
CI2703030	(300+300)x2700	(11.81"+11.81") x 8'10.25"	1.62	17.4	106.52	234.8
CI1203030	(300+300)x1200	(11.81"+11.81") x 3'11.25"	0.72	7.8	51.75	114.1
CI903030	(300+300)x900	(11.81"+11.81") x 2'11.44"	0.54	5.8	43.66	96.1
CI603030	(300+300)x600	(11.81"+11.81") x 1'11.63"	0.36	3.9	30.02	66.2
CI303030	(300+300)x300	(11.81"+11.81") x 11.81"	0.18	1.9	18.99	41.9

Components Stopend Panel & Filler Plates

■ Stopend Panel

Code	kg	lbs
WSEP	8.82/m	5.9/ft

■ Filler Plate

Code	mm	ft	kg	lbs
FP27	2700	10.25'8"	48.8	107.6
FP12	1200	11.25'3"	24.3	53.6

Filler Plates close any gap from 60mm to 360mm | 2.36" to 14.17".



WSEP



FP27

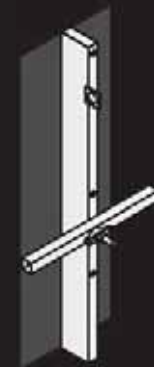

FP12

BUILD STRONG BUILD WITH QUALITY

Alignment Coupler

Item Code	kg	lbs
WCPL	4.05	8.9

Permissible tension force is 20kn | 4946 lbs and maximum clamping length is 220mm | 8.66".

Fixed Alignment Coupler

Item Code	kg	lbs
WFCPL	4.05	8.9

Compensation Walers

Item Code	kg	lbs
WCWL1300	17.09	37.7
WCWL850	12.50	27.6

Permissible bending moment 4.4kn/m | 301 lbs/ft.

90° Walers

Item Code	90° Wallers	kg	lbs
WPWL85	for 90° internal corner	12.48	27.5
WPWL50	for 90° internal corner	9.50	20.9

WCPL

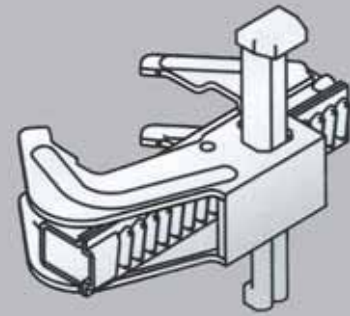

WFCPL

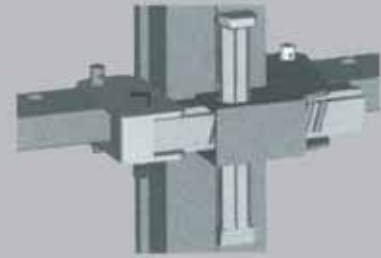

WCWL1300

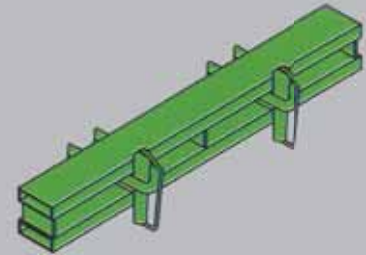

WPWL85

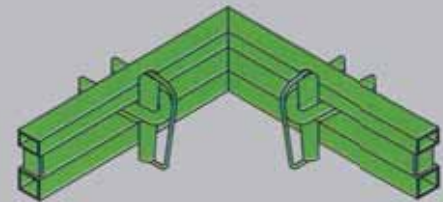

Wall Formwork



Components Fasteners & Lifting Hook

Ties

Code		kg	lbs
WTR	Tie Rod	1.32/m	0.9/ft
WCSCP	Cast Steel Counterplate	0.61	1.3
WCSWN	Cast Steel Wingnut	0.36	0.8
WPST	Plastic Spacer Tube	0.22	0.5
WPC	Plastic Cone	0.005	0.01
WPLG	Plastic Plug	0.003	0.007
WST	Stopened Tie	1.2	2.6
WHT	Hook Tie	0.64	1.4
WHTH	Hook Tie Head	0.42	0.9

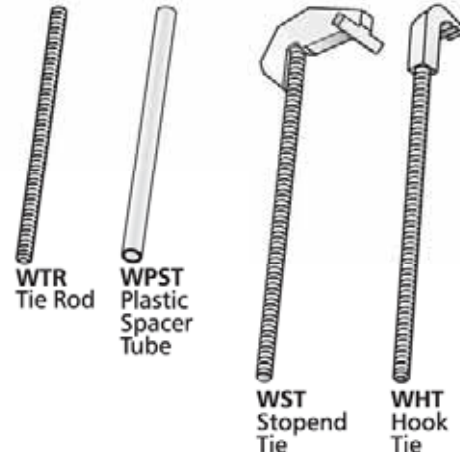

WCSWN
Cast Steel
Wingnut

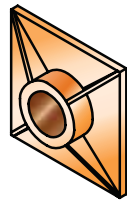

WCSCP
Cast Steel
Counterplate



WPC
Plastic Cone

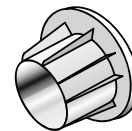

WPLG
Plastic Plug

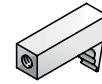

WHTH
Hook Tie Head

Taper Tie

Code		kg	lbs
WTTT	Taper Tie up to 24" 600mm wall	11	24

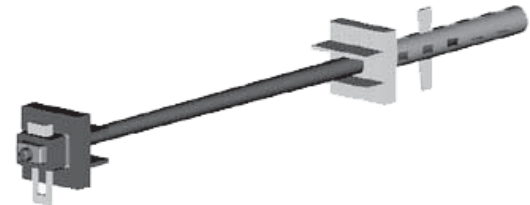

WTTT
Quick Release Taper Tie

Ancillary Components

Code		kg	lbs
WLH	Lifting Hook	6.99	15.4
WTB2	Tie Bracket	0.36	0.8



WLH
Lifting
Hook



WTB2
Tie bracket

Supports

Code		kg	lbs
WSCB	Scaffold Bracket	15.75	34.7
WPPP	Push-pull prop	22.4	49.4
WKB	Kicker brace	13.96	30.8
WKC	Kicker/Prop Connector	1.96	4.3
WBC2	Brace Connector-2	0.95	2.1

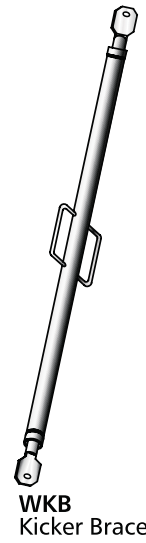
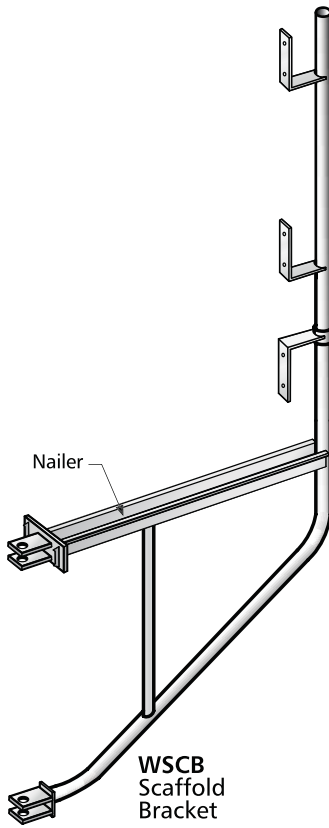

TB1 Retaining Wall



TABLA Modular Panel Wallform System (TB2) - Light Duty



TABLA Modular Panel Wallform System (TB2) - Light Duty



TB2 - TABLA Modular Panel Wallform System

The most important aspect of successful structural construction is the formwork system. The Tb2 System will always offer the most trustful, secure, efficient and cutting edge of formwork technology for various structures. The Tb2 System is an ingenious small-panel formwork system that was specially designed for cost-effective forming of concrete elements.

Tb2 system is a complete, crane-independent formwork system enabling you to shutter all structures to perfection in an inexpensive and cost-effective manner. All of the panels belonging to this system are relatively light and handy that they can be handled and fitted by a maximum of two people.

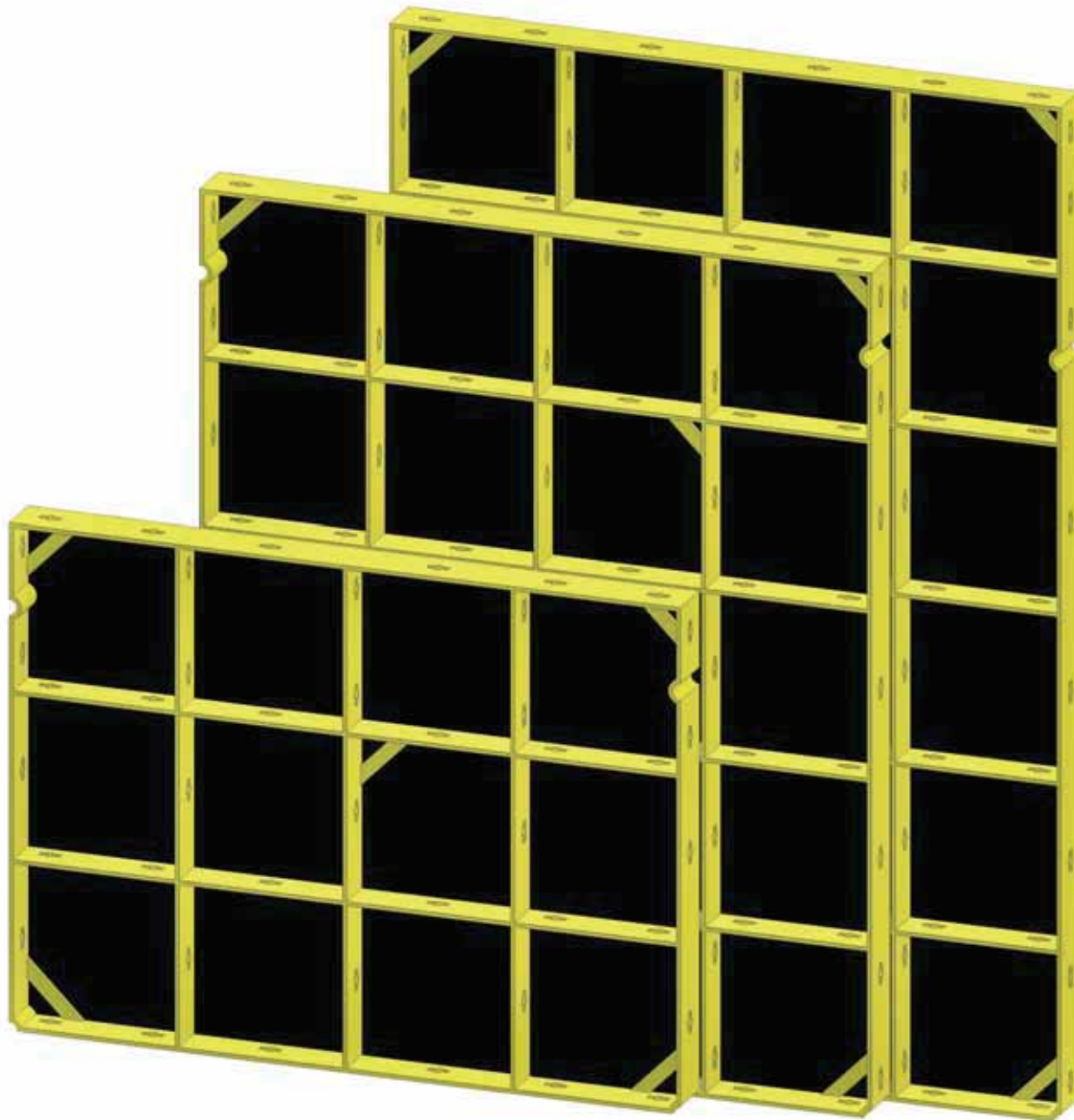

System Features



BUILD STRONG BUILD WITH QUALITY



TB2 Core Wall

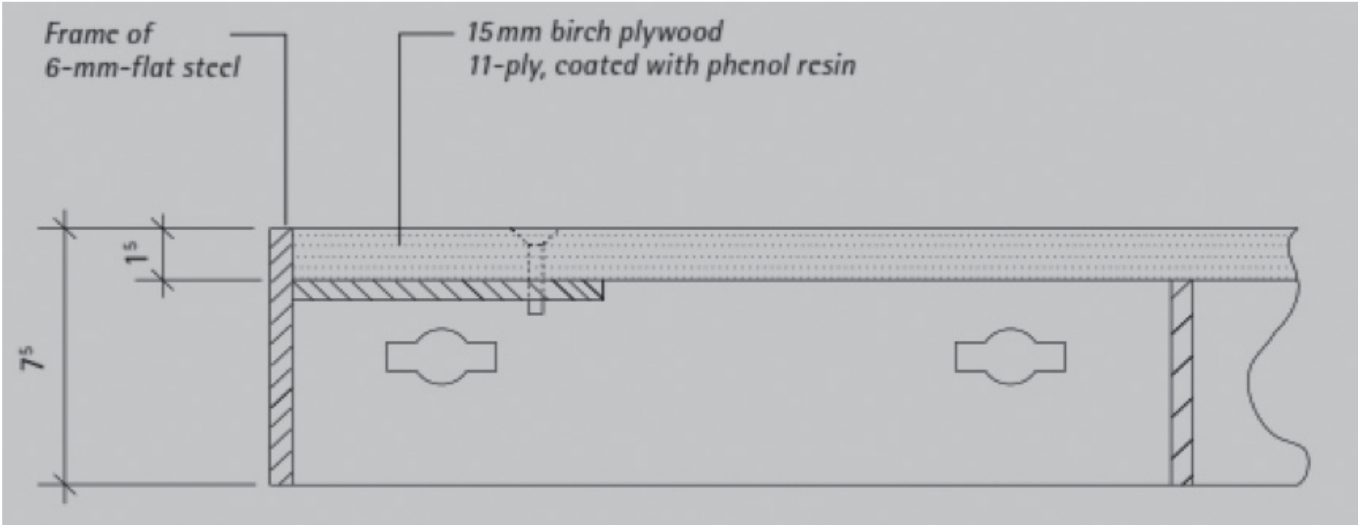

This is another panel system in our wall formwork fleet where the worker needs only a hammer to connect the panels which makes this system very efficient and fastest to erect due to lightweight panels.

System Features



Tb2 system panels are made from steel frames which make the panels more rigid, more robust and lighter than competitor panels. The Tb2 system enables large savings in timber elements on site.

Can be used without requiring a crane, which dramatically reduces construction costs.

The quality of the 15mm plywood sheet overlay on the face provides long life and a high quality finish for the concrete.

The Tb2 system has a wide range of panel sizes, allowing virtually any configuration to be erected. The erection and striking of an Tb2 system is fast and straight forward and only needs a team of two, saving time and money.

Panels are attached together using key Bolts which improves preparation times.

The Tb2 system comprehensive range of accessories enables it to be used in an extensive range of construction projects.

Tb2 system panels can be used with steel soldiers or steel walers to create large crane handled formwork shutters.

Tb2 System Panels:

The Tb2 system panels are lightweight and therefore can be erected very quickly by hand. The Tb2 system lets you construct extremely quickly and economically, even when no crane is available. On sites with a crane, it is also possible to lift several panels at a time, in gang-form.

The ingenious panel size grid makes for optimum adaptability to all construction site situations. The Tb2 system is perfectly tailored for use in the fields of residential construction and civil engineering.

Tb2 Panel Sizes:

Width 10,15,20,25,30,35,40,45,50,55,60,65,75,100cm

Height 75,125,150cm

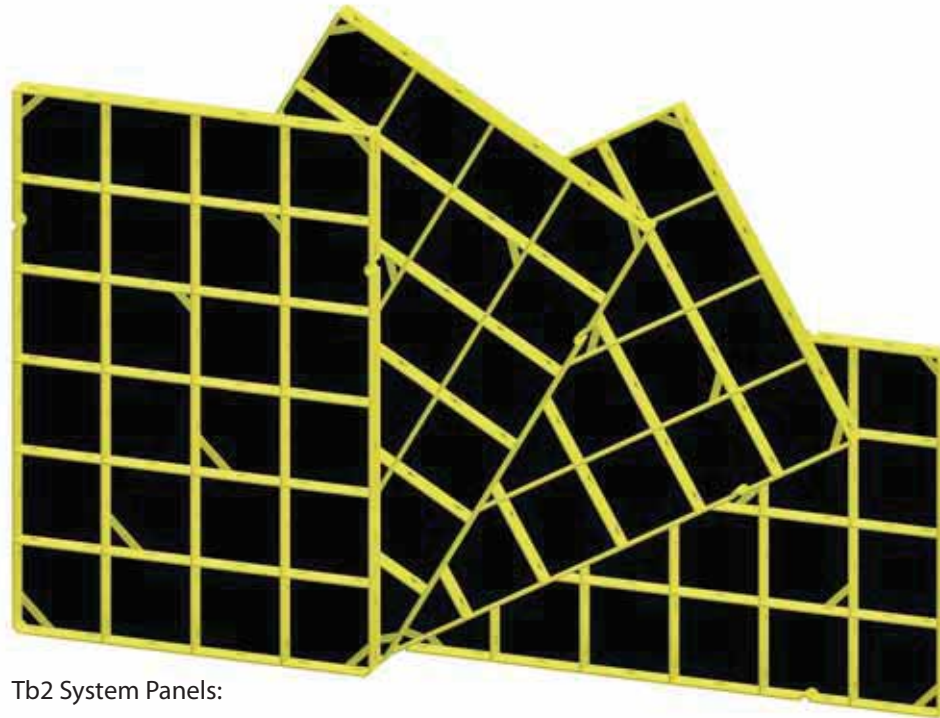

Tb2 System Panels:

Very flexible to assemble in required height. The TB2 system is designed to be used in equal ease and secured in both ways horizontally or vertically and with panels of different sizes.

Modular Panel Connections

Keybolt

- ◆ The easy and simple connection between panels is only require a hammer to fixing and loosening.
- ◆ It is beneficial in fast and easy operations and convenient dismantlement also ensuring the panel's strength, rigidity and flatness; it can also contribute to moulding a higher quality concrete face.
- ◆ The Keybolt fixed in any direction vertically or horizontally to the framework quickly and securely.

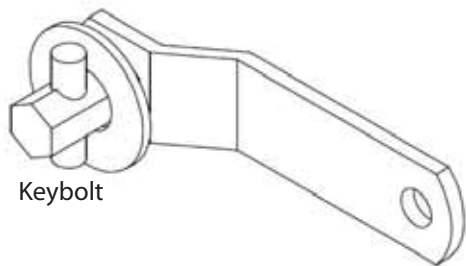

Keybolt

Two Sided Walls & Columns

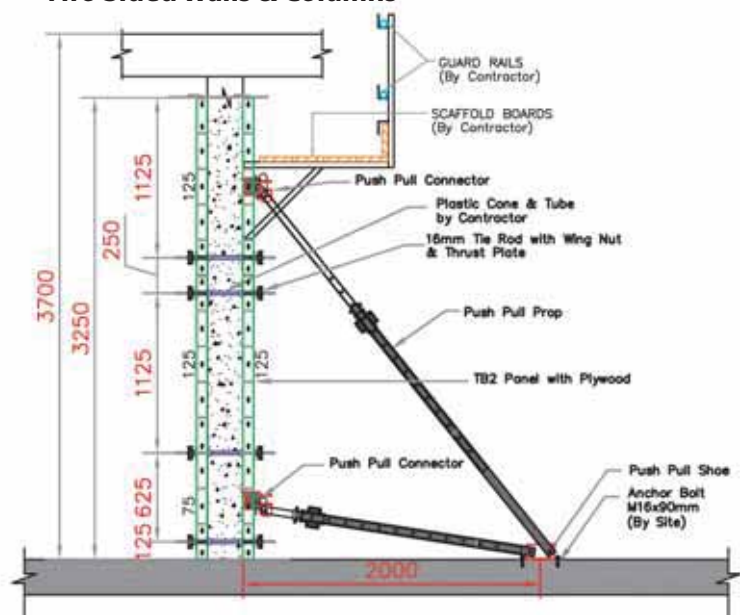

SECTION

TB-2 Modular Wall Panels

750 Series Wall Panels

Item Code	mm	ft	m ²	ft ²	kg	lbs
T2P75100	750 x 100	5.53 '2" X 3.94 '0"	0.075	0.807	6.25	13.78
T2P75150	750 x 150	5.53 '2" X 5.91 '0"	0.113	1.211	6.85	15.10
T2P75200	750 x 200	5.53 '2" X 7.88 '0"	0.150	1.615	7.70	16.98
T2P75250	750 x 250	5.53 '2" X 9.84 '0"	0.188	2.018	8.35	18.41
T2P75300	750 x 300	5.53 '2" X 11.81 '0"	0.225	2.422	8.90	19.62
T2P75350	750 x 350	5.53 '2" X 1.78 '1"	0.263	2.826	9.40	20.73
T2P75400	750 x 400	5.53 '2" X 3.75 '1"	0.300	3.229	10.20	22.49
T2P75450	750 x 450	5.53 '2" X 5.72 '1"	0.338	3.633	10.70	23.59
T2P75500	750 x 500	5.53 '2" X 7.69 '1"	0.375	4.037	13.35	29.44
T2P75550	750 x 550	5.53 '2" X 9.66 '1"	0.413	4.440	13.95	30.76
T2P75600	750 x 600	5.53 '2" X 11.63 '1"	0.450	4.844	14.60	32.19
T2P75650	750 x 650	5.53 '2" X 1.59 '2"	0.488	5.247	15.20	33.52
T2P75750	750 x 750	5.53 '2" X 5.53 '2"	0.563	6.055	18.40	40.57
T2P751000	750 x 1000	5.53 '2" X 3.38 '3"	0.750	8.073	23.60	52.04



Wall Formwork

1250 Series Wall Panels

Item Code	mm	ft	m ²	ft ²	kg	lbs
T2P125100	1250 x 100	1.22 '4" X 3.94 '0"	0.125	1.346	10.30	22.71
T2P125150	1250 x 150	1.22 '4" X 5.91 '0"	0.188	2.018	11.05	24.37
T2P125200	1250 x 200	1.22 '4" X 7.88 '0"	0.250	2.691	12.35	27.23
T2P125250	1250 x 250	1.22 '4" X 9.84 '0"	0.313	3.364	13.25	29.22
T2P125300	1250 x 300	1.22 '4" X 11.81 '0"	0.375	4.037	14.00	30.87
T2P125350	1250 x 350	1.22 '4" X 1.78 '1"	0.438	4.709	14.95	32.96
T2P125400	1250 x 400	1.22 '4" X 3.75 '1"	0.500	5.382	15.90	35.06
T2P125450	1250 x 450	1.22 '4" X 5.72 '1"	0.563	6.055	16.65	36.71
T2P125500	1250 x 500	1.22 '4" X 7.69 '1"	0.625	6.728	20.95	46.19
T2P125550	1250 x 550	1.22 '4" X 9.66 '1"	0.688	7.400	21.90	48.29
T2P125600	1250 x 600	1.22 '4" X 11.63 '1"	0.750	8.073	22.75	50.16
T2P125650	1250 x 650	1.22 '4" X 1.59 '2"	0.813	8.746	23.60	52.04
T2P125750	1250 x 750	1.22 '4" X 5.53 '2"	0.938	10.091	28.95	63.83
T2P1251000	1250 x 1000	1.22 '4" X 3.38 '3"	1.250	13.455	36.75	81.03

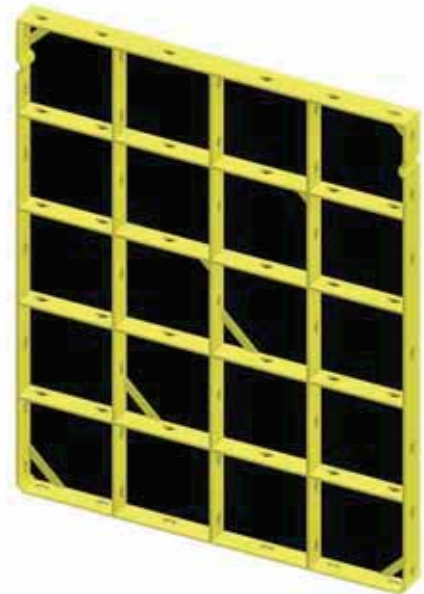

1500 Series Wall Panels

Item Code	mm	ft	m ²	ft ²	kg	lbs
T2P150100	1500 x 100	11.06 '4" X 3.94 '0"	0.150	1.615	12.20	26.90
T2P150150	1500 x 150	11.06 '4" X 5.91 '0"	0.225	2.422	13.15	29.00
T2P150200	1500 x 200	11.06 '4" X 7.88 '0"	0.300	3.229	14.50	31.97
T2P150250	1500 x 250	11.06 '4" X 9.84 '0"	0.375	4.037	15.95	35.17
T2P150300	1500 x 300	11.06 '4" X 11.81 '0"	0.450	4.844	16.55	36.49
T2P150350	1500 x 350	11.06 '4" X 1.78 '1"	0.525	5.651	17.45	38.48
T2P150400	1500 x 400	11.06 '4" X 3.75 '1"	0.600	6.458	18.70	41.23
T2P150450	1500 x 450	11.06 '4" X 5.72 '1"	0.675	7.266	19.60	43.22
T2P150500	1500 x 500	11.06 '4" X 7.69 '1"	0.750	8.073	24.55	54.13
T2P150550	1500 x 550	11.06 '4" X 9.66 '1"	0.825	8.880	25.65	56.56
T2P150600	1500 x 600	11.06 '4" X 11.63 '1"	0.900	9.688	26.65	58.76
T2P150650	1500 x 650	11.06 '4" X 1.59 '2"	0.975	10.495	27.80	61.30
T2P150750	1500 x 750	11.06 '4" X 5.53 '2"	1.125	12.110	33.85	74.64
T2P1501000	1500 x 1000	11.06 '4" X 3.38 '3"	1.500	16.146	43.45	95.81



Inside Corner

Item Code	Size	kg	lbs
T2IC	750x150x150 mm	9.60	21.17
T2IC	1250x150x150 mm	14.85	32.74
T2IC	1500x150x150 mm	19.40	42.78



Inside Corner

Outside Corner

Item Code	Size	kg	lbs
T2OC	750x60x60 mm	3.60	7.94
T2OC	1250x60x60 mm	6.00	13.23
T2OC	1500x60x60 mm	7.90	17.42

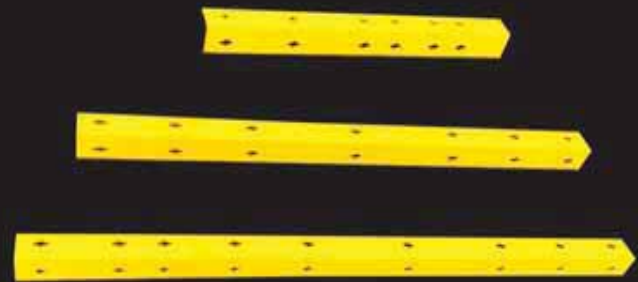

Outside Corner

Filler Plate

Item Code	Size	kg	lbs
T2FP	750x80x80 mm	4.10	9.04
T2FP	1250x80x80 mm	6.70	14.77
T2FP	1500x80x80 mm	7.50	16.54



Filler Plate

Polygonal Filler Post Out Side & Inside

Item Code	Size	kg	lbs
T2PFPO759 T2PFPI759	750x90 mm 750X45mm	9.60	21.17
T2PFPO1259 T2PFPI1259	1250x90 mm 1250X45mm	14.85	32.74
T2PFPO1509 T2PFPI1509	1500x90 mm 1500X45mm	19.40	42.78



Polygonal Filler Post Out Side & Inside

Panel (Filler Post)

Item Code	Size	kg	lbs
T2PFP	750x50 mm	5.55	12.24
T2PFP	1250x50 mm	8.25	18.19
T2PFP	1500x50 mm	10.10	22.27

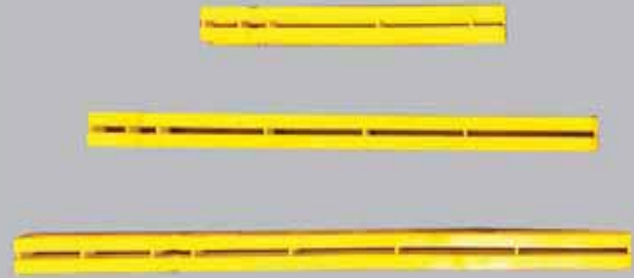

Panel (Filler Post)

Platform Bracket

Item Code	Item Name	kg	lbs
T2PFB	PLATFORM BRACKET	10.40	22.93

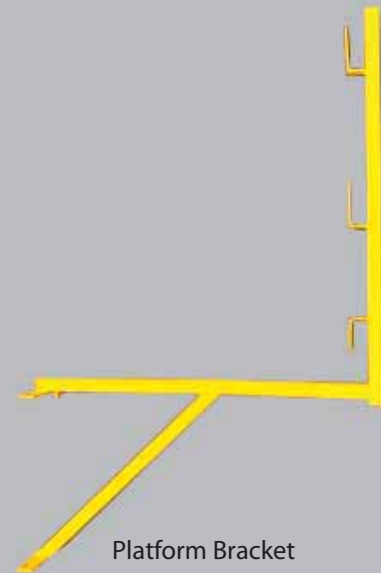

Platform Bracket

Hinged Corner Post

Item Code	Size	kg	lbs
T2HCP	750x95x95 mm	10.80	23.81
T2HCP	1250x95x95 mm	16.00	35.28
T2HCP	1500x95x95 mm	20.40	44.98

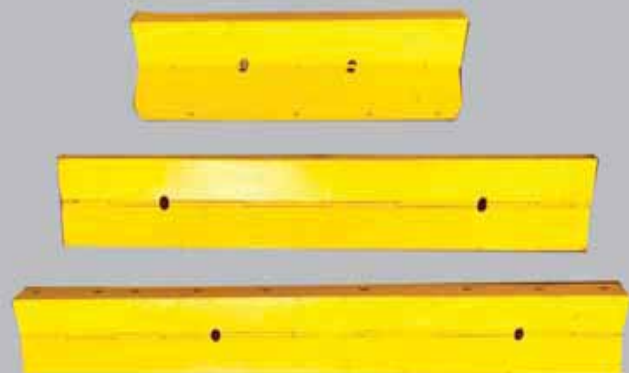

Hinged Corner Post

Components

BUILD STRONG BUILD WITH QUALITY

Item Code	Item Name	kg	lbs
T2KB	Key Bolt	0.20	0.44
T2LH	Lifting Hook	3.90	8.60
T2AT	Assembly Tools	3.55	7.83
T2SS	Spacer Strip 1330x60 mm	3.60	7.94



Lifting Hook

Assembly Tools

Spacer Strip

Item Code	Item Name	kg	lbs
B107003	Push Pull Prop	22.40	49.4
EMS	Kicker / Prop	1.96	4.3
B107005	Tb2- Brace Conn	0.95	2.1
WTR161000	Tie Rod	1.32/m	0.9/ft
WGNT	Wing Nut	0.360	0.8
WGPE	Wing Plate	0.610	1.3
AF35	A-Frame	205	452

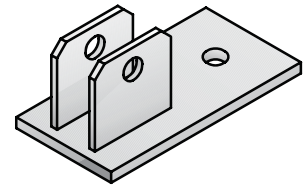
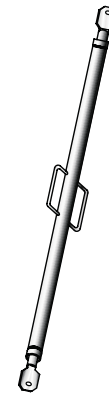

Push Pull Prop

Kicker Brace

Kicker/prop Connector(Shoe)

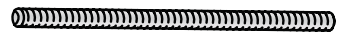
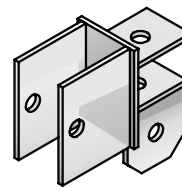

Brace Connector

Tie Rod

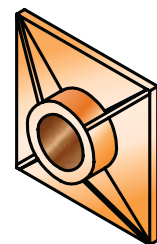
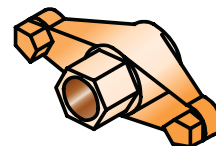

Wing Nut-16 Mm H/D

Cast Steel Counterplate

Gang Wallform System



Gang Wallform System



The Gang Wall Formwork System

The Gang Wall Formwork System was developed with a combination of Double Steel Walers, Aluminium Beams or Timber Beams. This system is widely recognized as one of the most adaptable formwork systems available to contractors easy to erect, align and dismantling. The Gang Waling Formwork system adapts to all heights and widths accommodates every pressure and meets all construction demands.

The basis of the Waling System is the Aluminium beam. The waling system formwork elements are assembled quickly and easily by connecting the aluminium beams to the steel walers by means of T-bolt clamps. Dismantling of elements is done as simply as the erection of the system. The advantage is that the Gang waling formwork system provides a high adaption and easy reassembling when ground plans of the structure change frequently.

Retaining Wall Form

The Retaining Wall Form System consists of a aluminium beam, plywood, A-frame, double push-pull prop, double channel waler, soldier beam, walkway bracket & tie rod with its fasteners.



Core Wallform

The Core Wall Form System consists of a aluminium beam, plywood, double push-pull prop, double channel waler, soldier beam, walkway bracket & tie rod with its fasteners.

Gang formwork system is an extremely flexible and cost effective wall formwork system suitable for walls and columns. It uses all standard components, is easy to assemble, with tight panel joints, internal or external corners and gives an excellent concrete finish. It can be used for virtually any shape or practical height.

BENEFITS

- For the efficient and economical creation of concrete with a high quality of finish.
- Optimized formwork with regard to defined concrete pressure.
- Common standard accessories.
- Easy jointing of walers and aluminum beams.
- Simple and tight panel joints with connectors.
- Lower transport volume when moving the items in dismantled state.
- Simple and tight panel joints with connectors.
- Easily replaceable plywood in case of damage.



Column Wallform

The Column Wall Form System consists of a aluminium beam, plywood, double push-pull prop, double channel waler, soldier beam, walkway bracket & tie rod with its fasteners.

Two Sided Walls and Columns

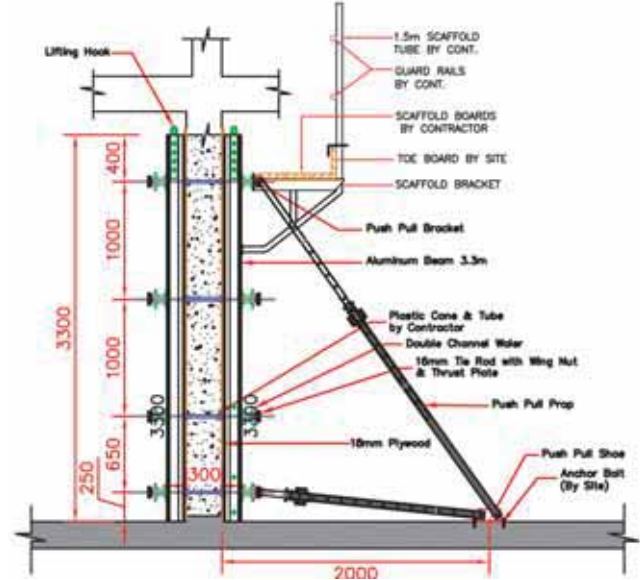

SECTION

Wall Formwork



Components

BUILD STRONG BUILD WITH QUALITY

Item Description	Size		Weight	
	mm	ft	Kg	lbs
Aluminum Beam	3300	10' 9.92"	10.56	23.28



Aluminum Beam

Item Description	Weight	
	Kg	lbs
Push Pull Prop set	32	70.56
Kicker/ Prop connector (Shoe)		
Brace conn.-2/ Set (Panel conn.)		



Push Pull Prop set

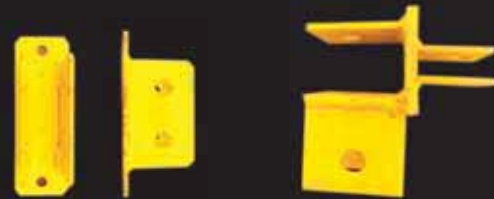

Kicker/ Prop connector (Shoe)

Item Description	Size		Weight	
	mm	ft	Kg	lbs
Double channel Waler	600 X 100	1' 11.62" X 0' 3.94"	11.32	24.96
	900 X 100	2' 11.43" X 0' 3.94"	16.76	36.96
	1200 X 100	3' 11.24" X 0' 3.94"	22.63	49.90
	1500 X 100	4' 11.06" X 0' 3.94"	28.29	62.38
	1800 X 100	5' 10.87" X 0' 3.94"	33.95	74.86
	2400 X 100	7' 10.49" X 0' 3.94"	45.26	99.80
Double Corner Waler	500 X 500	1' 7.69" X 1' 7.69"	12.74	28.09



Double Channel Waler



Double Corner Waler

Item Description	Weight	
	Kg	lbs
Corner Connecting Plate	9.82	21.65



Corner Connecting Plate

Item Description	Weight	
	Kg	lbs
Angle Tie Bracket	2.64	5.82



Angle Tie Bracket

Components

Item Description	Weight	
	Kg	lbs
Internal Angle plate	8.22	18.13

Item Description	Weight	
	Kg	lbs
Adjustable waler extension 80cm.	4.98	10.98

Item Description	Weight	
	Kg	lbs
Connecting Pin	0.4	0.88

Item Description
Universal clamp

Item Description	Weight	
	Kg	lbs
Scaffold Bracket (Gang wall)	10.3	22.71
Lifting hook for Aluminium beam	4.08	9.00
Timber	***	***
Plywood (18mm)	***	***



Internal Angle plate



Adjustable waler extension 80cm.



Connecting Pin



Universal clamp



Scaffold Bracket (Gang wall)



Lifting hook



Timber



Plywood (18mm)

Wall Formwork





Scaffolding

AD Lock Scaffolding System

Cuplock

STANDARDS

The vertical elements in 9 standard sizes have a joint casting every 0.5m intervals. The top joint castings are made of high grade steel to allow the rigors of daily use. The bottom joints are high grade pressed steel.

Item Code	Length (m)	Weight (Kg)
AD1100	1.0	5.08
AD1130	1.3	6.85
AD1150	1.5	7.62
AD1180	1.8	9.38
AD1200	2.0	10.15
AD1230	2.3	11.92
AD1250	2.5	12.68
AD1280	2.8	14.46
AD1300	3.0	15.22

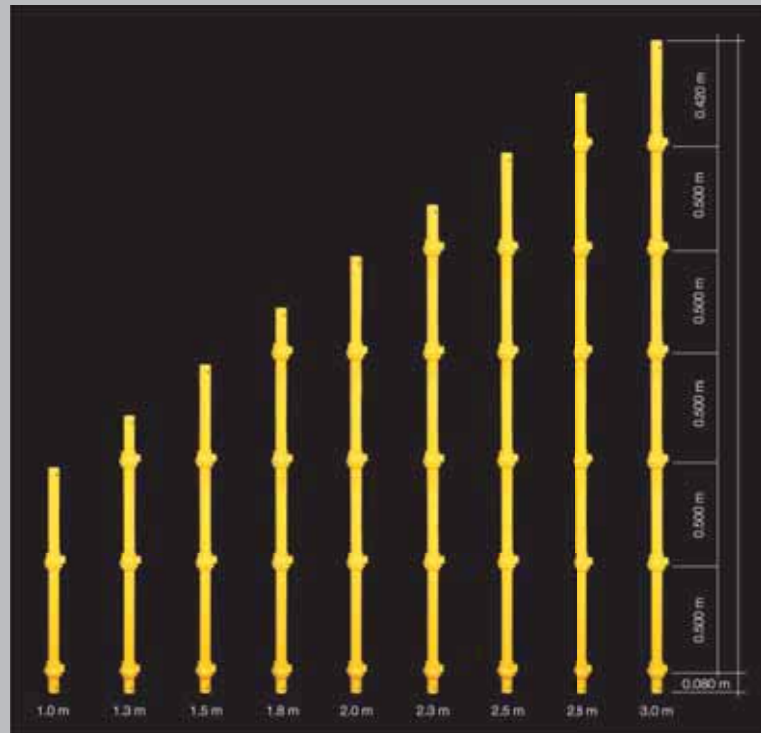

BUILD STRONG BUILD WITH QUALITY

LEDGERS

Horizontal element in 9 standard sizes with the locking element - the ledger end plate made of forged steel.

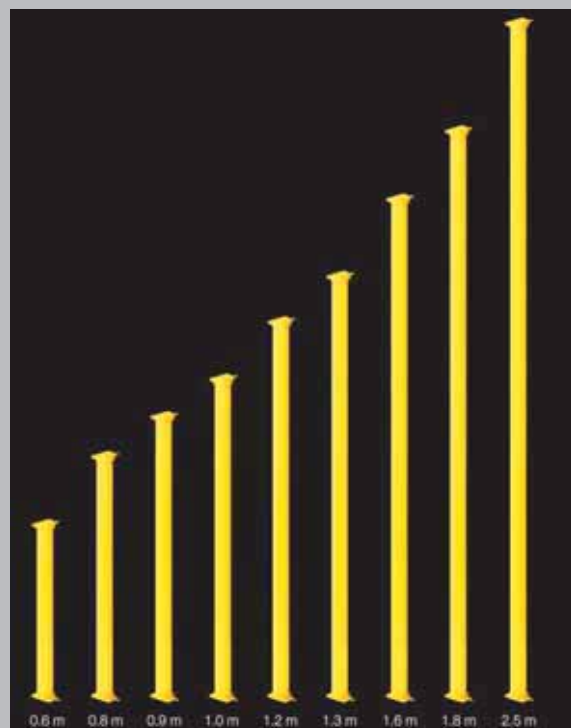

Item Code	Length (m)	Weight (Kg)
AD260	0.6	2.34
AD270	0.8	3.08
AD290	0.9	3.41
AD2100	1.0	3.77
AD2120	1.2	4.48
AD2130	1.3	4.84
AD2160	1.6	5.91
AD2180	1.8	6.60
AD2250	2.5	9.12

AD Lock Scaffolding System

VERTICAL COMPONENTS

Allowable compressive load when used as an access scaffold.

- The allowable loads given are based on a safety factor of 4:1 on testing to ultimate failure.
- The allowable loads are only valid if the access scaffold is adequately braced to prevent horizontal movement.



Centres of Horizontal Members (m)	4 Horizontal Members (Kg)
2.0	2950
1.5	3640

3 Horizontal Members (Kg)	2 Horizontal Members (Kg)
2102	1930
3070	2750

Centres of Verticals (m)	Allowable Center Point Load (Kg)	Allowable Uniformly Distributed Load (N/m)
0.9	482	48.6
1.2	364	29.1
1.5	290	17.4
1.8	240	11.9
2.0	210	8.90
2.5	180	6.85

HORIZONTAL COMPONENTS

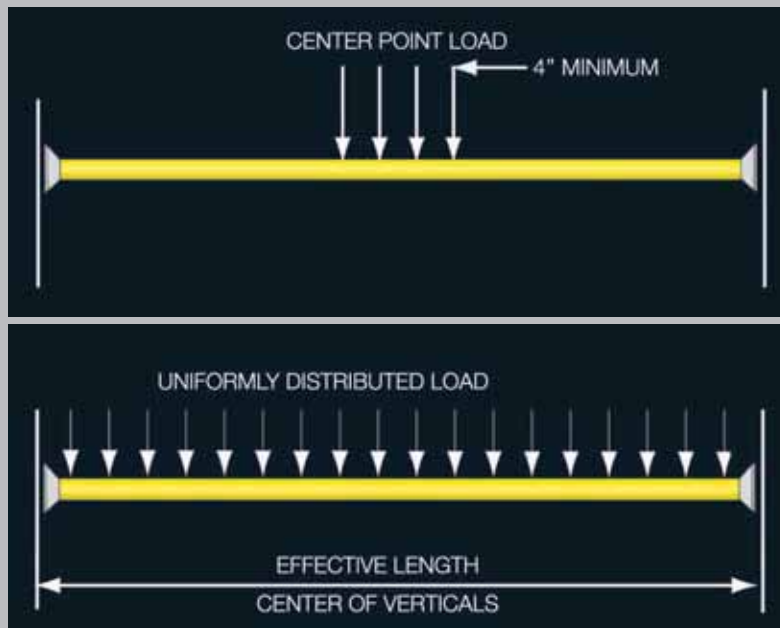

- The allowable loads given are based on 4:1 on testing to ultimate failure.

TECHNICAL INFORMATION ON SLAB

SUPPORTING GRIDS

Bay sizes – inversely proportional to the slab/ beam thickness are shown in the following tabular form.

Slab / Beam Thickness (mm)		Bay Size (N/m)
From	To	
150	250	2.5 x 1.6
250	350	2.5 x 1.3
250	350	1.8 x 1.8
350	400	1.8 x 1.6
400	300	1.8 x 1.3
500	750	1.2 x 1.3
750	1000	1.2 x 1.0
1000	1750	1.2 x 0.6

Scaffolding

AD Lock Scaffolding System



THIS SYSTEM HAS COUNTLESS APPLICATIONS FOR BOTH INTERIOR AND EXTERIOR USE AND MEETS INTERNATIONAL STANDARD BS 1139:1994 PART - 3

The Maximum working height for interior work is 14 meters and exterior work is 10 meters.

Equal length braces, stabilizers and wheel legs can be interchanged between the single width (510 S/w) and the (520 D/W) mobile towers.

Maximum weight per platform is 225kg and for the entire tower is 600kg including the tower's weight.

The Wheels of the mobile tower is PU top and PP core.

The Towers are equipped with blank, unprocessed wooden toe board and wooden platforms.

Width available: 1.2, 1.4, 1.6, 2.0 meters.

Main frame height available: 1.5, 2.0 & 2.5 meters.

Length available: 1.8, 2.5 & 2.9 meters.

BUILD STRONG BUILD WITH QUALITY



AD Lock Scaffolding System

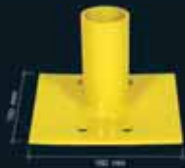

SOCKET BASE

Item Code	Size (mm)	Weight (Kg)
AD3SB	150 x 150 x 6	1.4



BASE JACK

Allows adjustments in height at base of the support

Item Code	Color	Length (mm)	Weight (Kg)
AD3ABJB	Black	760	4.10
AD3ABJG	Galv	760	4.20



'U' HEAD

Used with the universal jack to take on timber, aluminium or steel. When these are used as primary decking elements. It is also used as the base support when 'Steel Soldiers' are used to span across voids in the base slab.

Item Code	Length (mm)	Weight (kg)	Weight (kg)
AD3UH150	150	170	2.9
AD3UH200	200	186	5.0



UNIVERSAL JACK

Item Code	Color	Length (mm)	Weight (Kg)
AD3UJB	Black	760	3.1
AD3UJG	Galv	760	3.2

Allows adjustments in height at either the top or the bottom of the support when used in combination with socket base.



BASE PLATE

Used when combination of base jack, standard, universal jack. It transfer the load from the verticals.

INTERMEDIATE TRANSOM

When working platforms are required to be laid across spans greater than 2m, intermediate transoms are placed in between the ledger to reduce the span.



Item Code	Length (mm)	Weight (kg)
AD610	1.0	5.90
AD612	1.2	6.10
AD613	1.3	6.40
AD618	1.8	8.10
AD625	2.5	10.57

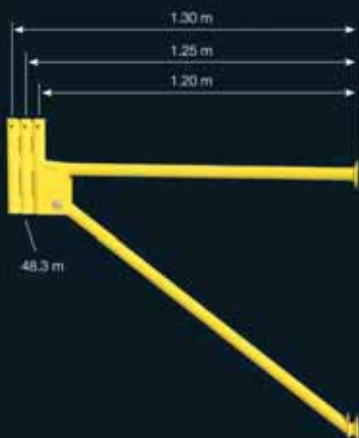

CANTILEVER FRAME

Used when support on the base slab is not possible, especially when drop beams around the perimeter of buildings need to be supported and the earth around the building is not leveled / compacted. In most cases it is from the first floor onwards to either support the drop beams or as access for the working personnel.

Three hollow tubes at the edge allows slight adjustment from 1.2m to 1.3m and they come in 2 sizes - 1.0m & 1.5m.

Item Code	Lift Height (m)	Weight (Kg)
AD3CF1	1.0	15.5
AD3CF	1.5	18.0

Sheet Metal Accessories

BUILD STRONG BUILD WITH QUALITY



Pressed Double Coupler



Pressed Swivel Coupler



Pressed Single Coupler



Pressed Sleeve Coupler



Pressed Inner Join Pin



Pressed Roofing Coupler



Putlong head



Pressed Fencing Coupler



Pressed Top End Clip



Pressed Ladder Clamp



Pressed Ladder Clamp



Drop Forged Double Coupler UK Style



Drop Forged Swivel Coupler UK Style



Drop Forged Single Coupler UK Style



Board Retaining Coupler



Drop Forged Swivel Coupler UK Style



Drop Forged Single Coupler UK Style



Board Retaining Coupler



Drop Forged Double Coupler German Style



Drop Forged Double Coupler German Style



Half Coupler German Style



Super Tie Coupler I



Supa Tie Coupler II



Girder Coupler

GALVANIZED TUBES

- Available 4.0mm or 3.2mm x 48.3mm OD
- Can be supplied in various lengths
- Fully complies to European Standard EN 39 and are embossed accordingly



GALVANIZED TUBES

WOODEN BOARD

- Fully conforms to BS 2482
- Banded with galvanized board bands at both ends
- Support at every 1.2m
- Kiln dried and have less than 16% moisture content
- Dimensions 38mm x 225mm x the desired length



WOODEN BOARD

LVL BOARD

- Fully conformant to OSHA regulations
- 29-CRF 1926 Sub Part L
- Dimensions 38mm x 235mm x the desired length. Various lengths can be supplied
- Modulus of elasticity of 2.0E



LVL BOARD

SCAFFOLD COMPOSITE BOARD (OIL AND GAS INDUSTRIES)

- Special made for Oil & Gas Industries
- Safer for use
- Longer life
- As per International standard

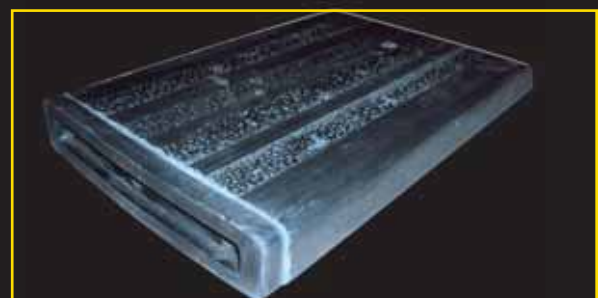

SCAFFOLD COMPOSITE BOARD

ADSF Shoring Frames



Shoring Frame

ADSF SHORING FRAME SYSTEM

ADSF Shoring Frame System is a high efficiency support structure for heavy duty horizontal concrete elements. The innovative prefabricated frame is the main component of a robust shoring system that will improve the quality and speed of concrete construction. The easily assembled frame with relevant system components provides an exceptional support system for slabs, beams and other horizontal formwork. As a completely toolless system with a low number of components and bolt free connections, the frame shoring system saves time compared to traditional scaffolding systems. The system requires less storage space with a compact transport scheme.



BUILD STRONG BUILD WITH QUALITY

FEATURES OVERVIEW

- High load bearing capacity of up to 62.3kN per leg.
- The frame is made of robust steel in various heights of 1.80m, 1.50m, 1.20m and 0.90m. All suitable for various heavy shoring uses.
- Large frame width for optimum stability.
- Variable inter-frame spacing.
- Offers maximum site use flexibility.
- Small number of system components.
- Crane time saving erection method.
- Frames are either painted, electroplated or hot dipped galvanized steel as per our customers request.
- The top U-head, screw jack and base plate allows a precision and fast structure handling.
- Primary decking options: ADSF aluminium beam 150, H2O timber beam and ADSF soldier beam.
Secondary decking options : ADSF aluminium beam 150 and H2O timber beam.
- High number of reuse cycles.
- Normally plywood by contractor, but can be provided by ADSF on request.
- Standard health and safety protection components to workers.

Recommended Safe Leg Loads for ADSF Shoring Frame 60mm Diameter Leg

Frame Size in mm.	Total Screw Adjustment Top + Bottom in mm.	Leg Load in kN									
		1	2	3	4	5	6	7	8	9	10
900x600 900x1200	600	62.3	53.4	48.9	48.0	47.2	46.3	45.4	44.5	43.6	42.7
	900	62.3	51.2	48.9	48.0	47.2	46.3	45.4	44.5	43.6	42.7
	1200	57.8	48.9	44.5	43.6	43.1	41.8	40.9	40.0	39.1	38.3
900x600 900x1200	600	62.3	53.4	48.9	48.0	47.2	46.3	45.4	44.5	43.6	42.7
	900	62.3	51.2	46.7	45.8	44.9	44.0	43.1	42.3	41.4	40.5
	1200	57.8	48.9	44.5	43.6	42.7	41.8	40.9	40.0	39.1	38.3
900x600 900x1200	600	53.4	53.4	48.9	48.0	47.2	46.3	45.4	44.5	43.6	42.7
	900	53.4	53.4	44.5	43.6	42.7	41.8	40.9	40.0	39.1	38.3
	1200	53.4	48.9	42.3	41.4	40.5	39.6	38.7	37.8	36.9	36.0
900x600 900x1200	600	53.4	53.4	48.9	48.0	47.2	46.3	45.4	44.5	43.6	36.0
	900	53.4	53.4	44.5	43.6	42.7	41.8	40.9	40.0	39.1	38.3
	1200	53.4	48.9	42.3	41.4	40.5	39.6	38.7	37.8	36.9	36.0
Number of Tiers (Frames / Tower)		1	2	3	4	5	6	7	8	9	10

ADVANTAGES & BENEFITS

- Shoring frame towers are the ideal shoring solution for high thick slabs and bridges.
- Used by a vast number of construction professionals, shoring frame systems provide support for both independent towers and fixed scaffolding, depending on application requirements.
- Shoring frame system is a completely toolless system with bolt free connections. The shoring frames are joined with coupling pin connector and the frames are secured against lift-off by using pigtail pins or bolt & nut.
- Shoring frames with low number of components saves time and money in assembly and dismantling due to reduced number of loose parts, versus traditionally assembled scaffold systems containing standards, ledgers and diagonal braces.
- The Welded frames without loose parts are light weight with a logical assembly sequence. Erecting and dismantling the towers is easy and safe even for relatively unskilled labour. This helps in lowering labour cost for the construction site.
- Shoring frame system offers unmatched time saving when compared with the assembly of traditional scaffolding made of separate standards and ledgers (approximately 30 faster).
- By using the pigtail pins or bolt & nut, the shoring tower can be assembled horizontally on the ground, then placed by a crane into position. This saves contractors time with minimal use of crane time.
- Shoring frame system is compatible with a variety of formwork girders such as aluminum beams, H20 timber beams, and ADSF soldier beams.
- Shoring frame system offers sustainability for site use with a reuse lifetime over many construction cycles with minimal waste.

ADSF PROPS

Built to British Standard BS 4074 and tested to BS 5507 Part 3: 1982 of high steel, these props can be used for a multitier purposes where an adjustable load bearing element required.

Height adjustments are possible by utilising a heavy duty pin through the slot in the outer tube holes (at regular intervals) in the inner tube. Adjustments are achieved through the rolled three cast iron collar.



BUILD STRONG BUILD WITH QUALITY

ADSF PROPS

Made of 3.0mm inner and 3.2mm outer tube they are available in four standard sizes offering extensions from 1.7m to 4.5m.

Item Code	Length (m)	Closed (m)	Open (m)	Weight (Kg)
AD30HD	3.0	1.7	3.0	15.0
AD35HD	3.5	2.0	3.5	16.8
AD40HD	4.0	2.5	4.0	18.5
AD45HD	4.5	3.0	4.5	20.0

MEDIUM DUTY PROP

A 2.0mm Inner and 2.0mm outer tube is used to make the Medium Duty Prop.

Item Code	Length (m)	Closed (m)	Open (m)	Weight (Kg)
AD30HD	3.0	1.7	3.0	10.0
AD35HD	3.5	2.0	3.5	12.0
AD40HD	4.0	2.5	4.0	13.0
AD45HD	4.5	3.0	4.5	14.0



Code of Safe Practices

Code of Safe Practices for erecting and dismantling vertical shoring

Give a copy of this document to your workers and post it on the job site.

It shall be the responsibility of all employers and users to read and comply with the following common sense guidelines, which are designed to promote safety in the erection, dismantling and use of vertical shoring. These guidelines are not all inclusive nor do they supplant or replace other additional safety and precautionary

measures to cover usual or unusual conditions. If these guidelines conflict in any way with any state, local, provincial or federal government statute or regulation, said statute or regulation shall supersede these guidelines and it shall be the responsibility of each user to comply therewith and also to be knowledgeable.

I. General Guidelines

- A) **Post these shoring safety guidelines** in a conspicuous place and be sure that all persons who erect, dismantle or use shoring are aware of them and also use them in Tool Box Safety Meetings.
- B) **Follow all state, local and federal codes, ordinances and regulations** pertaining to shoring.
- C) **Survey the job site.** A survey shall be made of the job site by a competent person for hazards, such as untamped earth fills, ditches, debris, high tension wires, unguarded openings, and other hazardous conditions created by other trades. These conditions should be corrected or avoided as noted in the following sections.
- D) **Plan shoring erection sequence** in advance and obtain necessary access equipment to accomplish the work.
- E) **Inspect all equipment before using.** Never use any equipment that is damaged or defective in any way. Mark it or tag it as defective. Then remove it from the job site.
- F) **A shoring drawing**, consistent with the shoring manufacturer's recommended safe working loads, shall be prepared by a qualified person (or professional engineer where required), and used on the job site at all times.
- G) **Erect, dismantle or alter shoring** only under the supervision of a qualified person.
- H) **Do not abuse or misuse the shoring equipment.**
- I) **Inspect erected shoring:** (a) immediately prior to concrete placement; (b) during concrete placement; (c) while vibrating concrete, and (d) after concrete placement until concrete is set.
- J) **Never take changes if in doubt regarding the safety or use of the shoring, consult your shoring supplier.**
- K) **Use shoring equipment** only for the purposed or in ways for which it was

intended. Use proper tools when installing equipment.

- L) **Erecting and dismantling of shoring** requires good physical condition. Do not work on shoring if you feel dizzy, unsteady in any way or are impaired in any way by drugs or any other substance.

II. Guidelines for Erection and Use of Shoring

- A) **Provide and maintain a solid footing.** The sills or cribbing for shoring shall be sound, rigid and capable of carrying the maximum design load without setting or moving.
- B) **Always use baseplates.** When sills or cribbing are used, base plates must be centered on them.
- C) **Adjusting screws shall be** used to adjust to uneven grade conditions. Maintain all screw adjustments within the recommended height for the design load.
- D) **Plumb and level all shoring frames and single post shores** as the erection proceeds. **DO NOT** force braces on frames. Level the shoring towers until proper fit can be made. Maintain all shoring towers plumb and level.
- E) **Maintain the shore frame spacings and tower heights** as shown on the shoring drawing. Where jobsite conditions require deviations from the shoring drawing, consult a qualified person.
- F) **Single post shores shall be stabilized in two directions.** Bracing shall be installed as the shores are being erected.
- G) **Single Post Shores More Than One Tier High** shall not be used. Where greater shore heights are required, consult the shoring supplier.
- H) **Adjustment of shoring to raise or lower formwork shall not** be made during concrete placement.
- I) **If motorized concrete equipment** is to be used, be sure that the shoring layout has been designed for use with this equipment and so noted on the layout, or drawing.

- J) **Use caution when erecting free standing towers.** Prevent tipping by guying or bracing when height exceeds 4 times the minimum base dimension and at lesser heights when stability is a concern.
- K) **Give special consideration to temporary loading.** Areas where re-bar, material or equipment is to be stored temporarily may need to be strengthened to meet these loads.
- L) **Do not climb cross braces.**
- M) **Use special precautions** when shoring from or to sloped surfaces.
- N) **Shoring loads are intended to be carried by vertical legs.** Loading of horizontal members may require special consideration. Consult your shoring supplier for allowable loads on horizontal members.
- O) **Avoid eccentric (off center) loads** on U-Heads, top plates and similar members by centering stringer loads on those members.

III. Guidelines for Dismantling Shoring

- A) **Do not remove braces or back off on adjustment screws or post shores** until proper authority is given.
- B) **Dismantled equipment** should be stockpiled in a planned manner and distributed to avoid concentrated loads on the partially cured concrete.
- C) **Use proper access equipment** in the dismantling process.

IV. Guidelines for Reshoring

- A) **Reshoring procedure** should be approved by a qualified engineer.

These safety guidelines (**Code of Safe Practice**) set forth common sense procedures for safely erecting, dismantling and using shoring. However, equipment and shoring systems differ, and accordingly, reference must always be made to the instructions and procedures of the supplier and or manufacturer of the equipment. Since field conditions vary and are beyond the control of the S.I.A., safe and proper use of shoring is the sole responsibility of the user.



CONTACT US

Office: Dubai

M - 02, Block B, Al Naboodah Building,
Sheikh Zayed Road, Al Quoz 3,
P.O. Box: 54009, Dubai, United Arab Emirates.
Tel: +971 4 347 4466 Fax: +971 4 340 0626
Email: info@adsf.ae

Factory: Umm Al Quwain

Makani No. 69573 26630,
New Industrial Area, Umm Al Thoub,
P.O. Box: 2474, UMQ, United Arab Emirates.
Tel: +971 6 767 2014 Fax: +971 6 767 2016



W W W . A D S F . A E